

Wall Pocket Site Survey – Swapping New Furniture (Tables & Benches) For Palmer Hamilton Wall Pockets Only

All items recommended. Items with an asterisk (*) necessary.

Please email completed form to your Palmer Hamilton customer service representative along with photos of your site.

Section 1 – Contact Information

Today's Date*

Survey Completed By*

Your Phone Number*

Your Email Address*

Dealer Name

Dealer Email

School Name*

School District*

City*

State*

Zip*

School Contact*

Anticipated Purchase Date





Section 2 – Wall Pocket Product Selection

These questions will help us pick out the proper model(s) to quote.

Total Number of Pocket Systems (Units)*

(Each Pocket is the sheet metal enclosure (cabinet))

Number of Table Sets in each Wall Pocket*

- Single 
- Double 
- Triple 
- Quad 
- Wheelchair 

What is the existing bench size (measure when deployed, open for use):

Height Width Length

What is the existing table size (measure when deployed, open for use):

Height Width Length

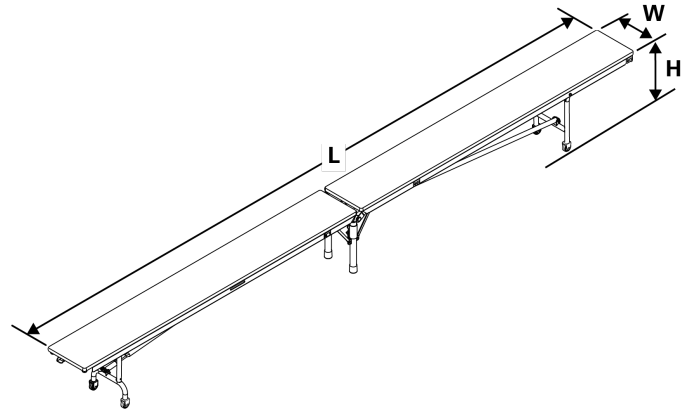

Are all the existing Wall Pocket Units the same size and type?*

- Yes
- No (please describe in detail)

Will any tables need to be wheelchair accessible during every setup?

- Yes No

Do the wall pockets have keyed lock mechanism on the mullion posts?

- Yes No

Do the wall pockets have a 'Z-lock' in the ceiling of each space? (refer to red arrow in picture below)

- Yes No

Do the wall pockets have 'intermediate track-lock' openings? (refer to green arrow in picture below)

- Yes No

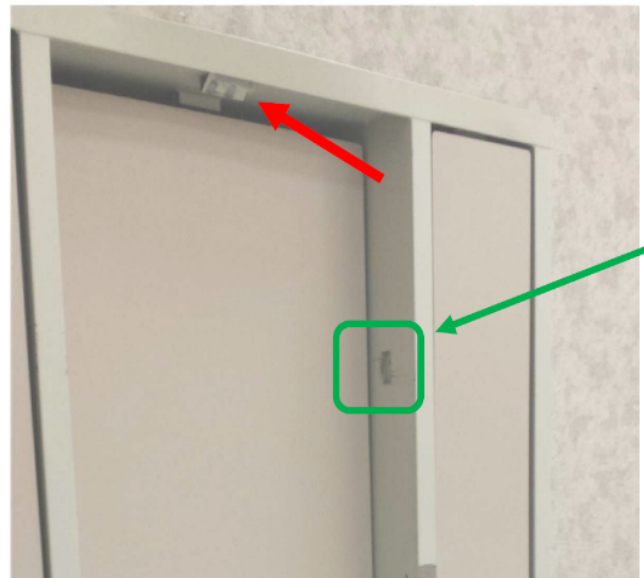

Is the condition of the existing wall pockets in good shape to accept new furniture?

- Yes
- No

(Check the lower track-lock slots and latch points in the ceiling.)

Please include closeup photos of the track-lock slots.

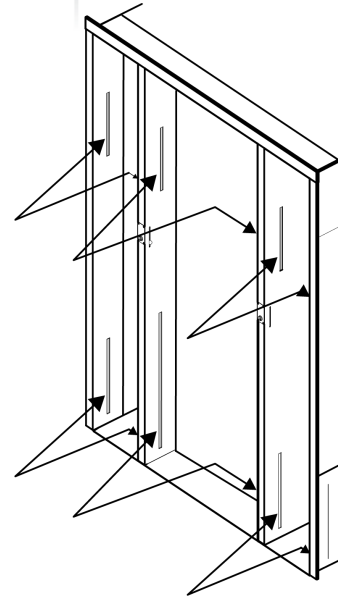

What is the current finished floor type?

- Linoleum
- Tile
- Concrete
- VAT
- Other – please describe in detail
- VCT
- Wood
- Sports Floor

Is the flooring below, level with or above the floor of the pocket?

- Below
- Level
- Above

Who will be responsible **for demolishing old systems and installing new?**

- School Staff
- Dealer Staff
- Other – Please describe in detail.
- Installer / Contractor
- Palmer Hamilton

Who is responsible **for removal and disposal of existing, tables and benches?**

- School Staff
- Dealer Staff
- Other – Please describe in detail.
- Installer / Contractor
- Palmer Hamilton

Section 4 – Installation

Do the wall pockets need to go up or down any stairs to get from the delivery truck to the room?*

- No
- Yes (please describe in detail)

Describe the smallest door opening (width and height) that the pockets need to fit through between the unloading area and the final installation site.*

Are there any other obstructions that may limit or inhibit delivery and installation of the product?

- No
 Yes (please describe in detail)

Who will **unload** this product from the truck at delivery site?*

- School Staff Installer / Contractor
 Dealer Staff Palmer Hamilton
 Other – Please describe in detail.

Are prevailing wages required for unloading and / or installation of the wall pocket system?*

- No
 Yes – please describe in detail.

Are there any restrictions that would prevent Palmer Hamilton contracting labor to unload and / or install?*

- No
 Yes – please describe in detail

Does the site have space to park a full-sized semi truck in the unloading area?*

- No Yes

Can the product arrived decked on load bars, or does all product need to be floor loaded? (Note: decked product may require a forklift and dock to be unloaded.)

- Product can be decked on load bars Product must be floor loaded only

Does the receiving site have a forklift or loading dock?* (remember pockets are large and heavy, they require a minimum of 4 people to unload by hand)

- Forklift Loading Dock
 Both Neither

Who is responsible for **removal and disposal of pallets, packaging and shipping materials** for this installation?* (Note: Dumpster should be provided by facility)

- School Staff Dealer Staff
 Installer / Contractor Palmer Hamilton
 Other – please specify in detail

Other Delivery and Installation Notes. Please attach another sheet if necessary.