

HUDDLE pod

Flexible solution to create quiet places in crowded and noisy environments.



DESCRIPTION

The Nook HUDDLE pod is a mobile solution to creating quiet spaces for getting away from hectic settings for personal exclusion or private meetings while still being connected to the group. Acoustic panels and pitched roof reduce ambient noise. Sturdy construction and modular design for easy upgrades and repairs. Under seat storage Power station (optional) for using and charging electronics and overhead light to create working environment. Options include open design, laminate or whiteboard back panel, upholstery choices, laminate colors and grades, personalization with logo or designed laminate panels and tabletop.

CONSTRUCTION

- Surfaces are M3 industrial grade particle board with HPL (decorative laminate) on top side and bottom. Depths vary from .75" to 1.125", depending needed strength. Both sides of all panels are covered with laminate, and edges are PVC edging.
- Sent knocked down, all panels assemble with screwdriver metal dowels and cams, and wood dowels.

- Four 4" total locking plate casters attach in each corners of the base.
- Electrical power strip attaches to bottom of unit.
- Power cords for unit protected from abuse by cabinet cover



- under table and a groove in the side panel and ceiling, with loop clamps to hold wire in place, covered by upholstery panels that attach with brackets.
- 33" x 4" shelf attaches to back wall above table surface.
- Power and charging unit fits in table top along back wall.
- Unit is available with or without upper back panel. This panel can be ordered with markerboard material with erasable writing surface.



Configure your pod to fit your surroundings.

LAMINATE OPTIONS

- Laminates are from our standard list of Wilsonart laminates. On standard models, all panels are the same laminate. Options include a contrasting laminate on tabletop and shelf, and customized logo panels.
 - Group 1:** Choose your colors from Wilsonart laminates. See their website. Palmer Hamilton standards are most colors in Type 335 laminate and finish type ending in -38 or -60. Exceptions may apply.
 - Group 2:** Standard Pionite, Nevamar and Formica laminates. Wilsonart laminates Type 335 and finish type ending in -1,-12,-16,-18,-19,-21,-22,-28,-52,-78, X-Grain, High Wear and Type 350 and 107 laminates.
 - Group 3:** Wilsonart Laminate Types 136 and 137.
 - Group 4:** Wilsonart Laminate Types 362 (VDL, Y-Type), 156 (Markerboard), 376-HD, 366, and 515.
- Custom logo laminates available at upcharge. Logos can be on surfaces A (table), B (sides), C (back), and in combination A or C only, B only, or B with either A or C but not both.

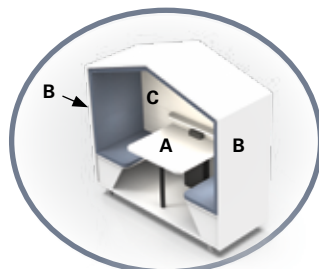

EDGING

- All edges finished with PVC edging. See our website for our standard color selections. Any of our standard colors available; same color is used throughout unit.

FRAME

- Table leg and electrical cabinet cover powder-coated in a choice of our standard colors.



Powder Coated Silver (SLV)

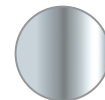

Chrome (CHR)



Black (BLK)

- Table is attached with sturdy leg weldment, and a back wall table mount.

UPHOLSTERY

- Seats, side and ceiling panels constructed of 3" foam.
- For this unit, we recommend a high performance fabric such as Stinson Ace (Grade 2 high performance fabric) available in many solid colors. See our website for other fabric options. Upgrade charges may apply. Customer owned materials may be provided but must be approved. Each unit requires 6 yards.
- Side and ceiling panels install with tabs that seat into metal brackets in four locations per panel.
- Each seat panel has two industrial Velcro strips on bottom to adhere to seat board.

POWER

- Unit must be plugged in to operate the overhead light and optional tabletop power unit.
- Attached to the bottom of the unit, out of the way yet easily accessible is the 120V 15A 6 outlet powerstrip. This strip allows for other items to be plugged in for use from within the pod, or consecutive power of a group of pods.
- Units are available with or without in-table Byrne Burelé power and data device with 3 power and one USB-A outlets for using equipment or charging electronics. If ordered, power device is attached to the tabletop and cord feeds to the power strip through a hole in floor panel, protected by the electrical cabinet cover.



LIGHT

- Units are equipped with an overhead LED lamp and shade.
- LED light is 10 Watts, 85W equivalent.
- Light is controlled by a supplied remote with color and mode options.

CAPACITY

- One unit seats 2 people, 275 pounds per person.
- Total recommended capacity is 550 pounds.

SHIPPING

- Unit ships KD. Step by step instructions included. Three people and standard hand tools required for assembly.

CERTIFICATIONS

- Nook HUDDLE pod is a Certified Autism Resource, awarded by the International Board of Credentialing and Continuing Education Standards (IBCCES)
- Palmer Hamilton's products are GreenGuard Gold certified.

REPLACEMENT PARTS

- Contact Palmer Hamilton if your upholstery or panels are damaged. We'll work with you on replacements, and may recommend that you replace additional pieces to avoid lot mismatch.

WARRANTY

5 year standard warranty. See our website.

SPECIFICATIONS

MODEL NUMBER	DESCRIPTION	OVERALL SIZE H x W x L (in)	WEIGHT (lbs)	SHIPPING DIMS W x D x H (in)
NOOKHUDDLE-300D	Unit with full back panel	77 x 78 x 30.5	550	39.5 x 80.75 x 20.5
	With open back panel	77 x 78 x 30.5	500	39.5 x 80.75 x 20.5

DIMENSIONAL DRAWINGS

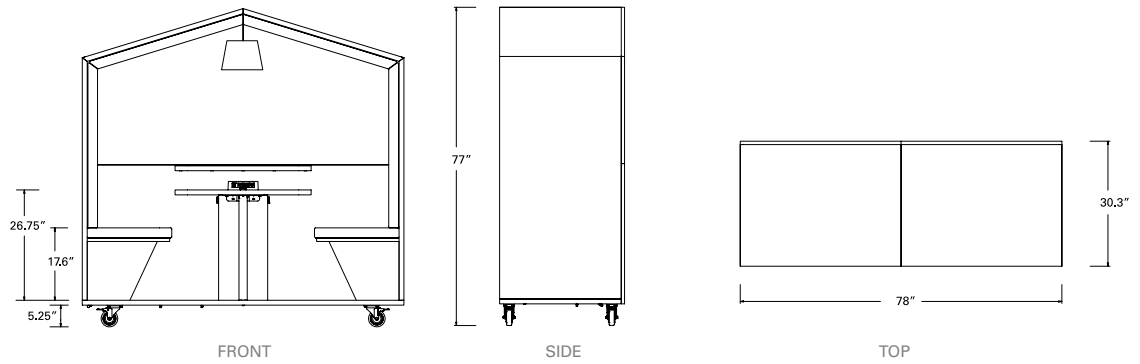

SUSTAINABILITY

Striving for sustainability in our products and manufacturing processes, Palmer Hamilton is a leader in environmental stewardship. It is our purpose to develop and design products that lessen the impact on the environment through the use of alternative materials and eco friendly technology.

Palmer Hamilton also endeavors to reduce our impact on the environment through sustainable energy and recycling processes throughout our corporate facilities.

Green product specification examples:

- Standard Particle Board is M3 industrial
- Grade 47lb. density fiberboard, 100% pre-consumer recycled wood fiber particle board.
- Meets California Air Resources Board (CARB-2) and TSCA Title VI.
- Meets California TB 117, Section 1 Flammability standard.
- No added urea-formaldehyde (NAUF) available.
- GreenGuard Gold certified products.

- All laminates used are GreenGuard certified.
- Adhesives are water based with no added urea-formaldehyde, low VOC emissions.
- Products are designed to be extremely flexible, lightweight, movable and storable. Designing flexible spaces reduces the overall footprint and building materials required for a building.
- Palmer Hamilton products are packaged using returnable (blanket wrapped) or recyclable (cardboard, wood and plastic) materials which can reduce disposal into landfills.

Corporately it is our policy to comply or exceed with all applicable environmentally regulations, employ contemporary recycling, waste reduction and sustainable practices. We train our staff on our environmental program and empower them to contribute and participate. Our commitment extends to our customers, our staff, our community and our suppliers.