

**SPEC SHEET OF-B6WBP**  
**6' EXPANDED BENCH WITH BACK - portable mount**

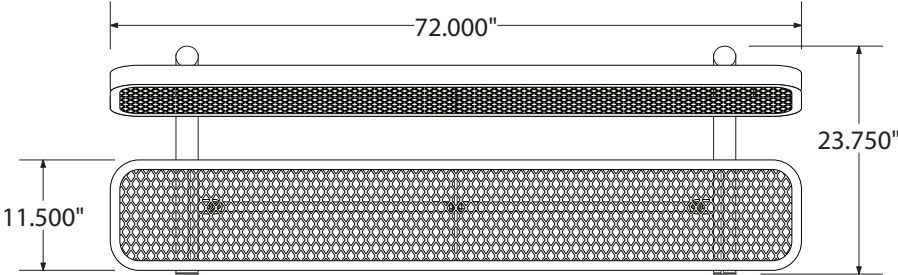

**top view**



**front view**

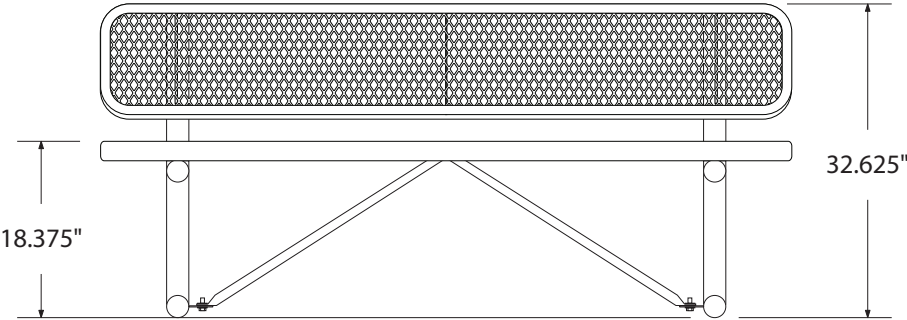

**side view**

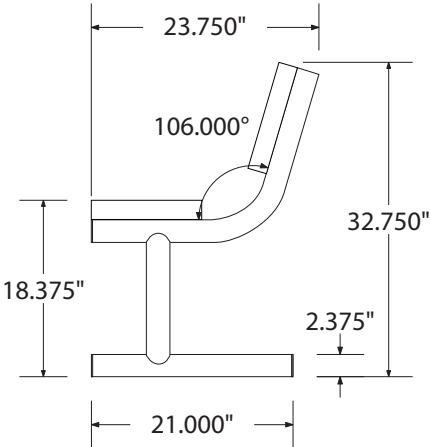

## product finish



### Coated Surfaces

- Thermoplastic coated
- Copolymer-based, environmentally safe
- Does not fade, crack, peel, or warp
- Applied at a thickness 25-30 mils.
- 5 year warranty on coating



### Construction

- Seats and tops - 9 gauge steel
- 2 $\frac{3}{8}$ " galvanized tubular steel understructure
- Black polyester powder coat on understructure
- Galvanized hardware

## mounting styles

P = Portable: no mount

SM = Surface Mount: concrete anchors through tabs welded to legs

IG= In-Ground:

J-rods set in concrete through tabs welded to legs [1] or long permanent legs with flatbar terminators set in concrete [2]

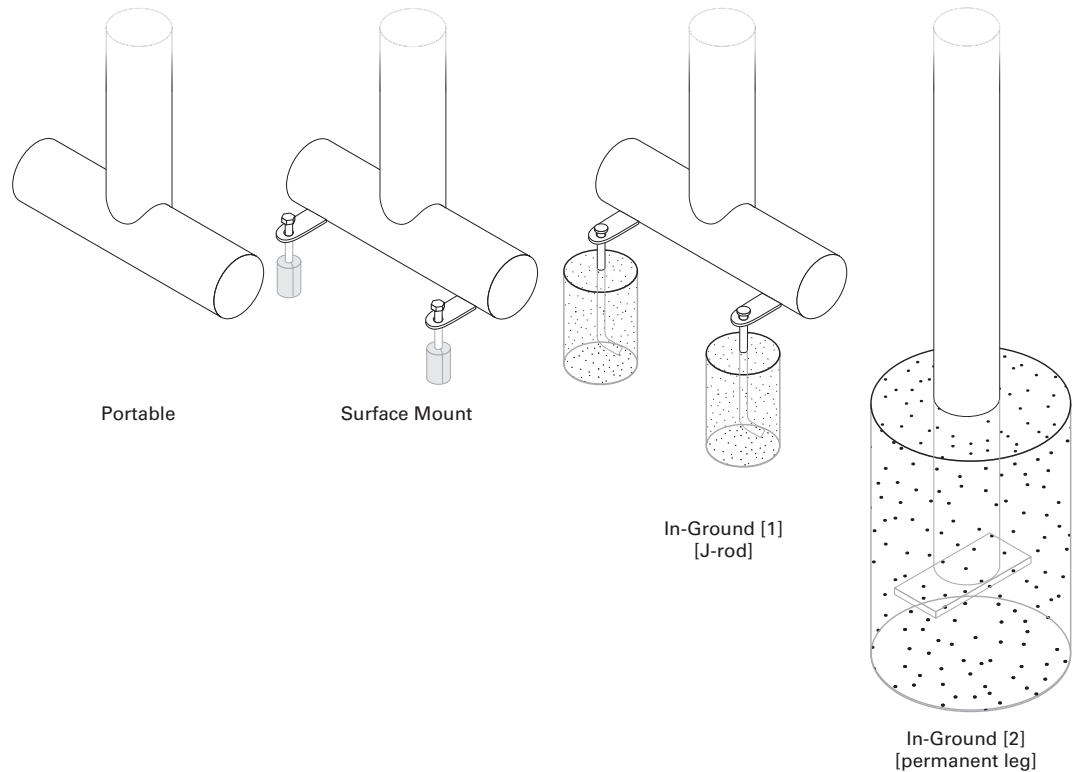

All design specifics subject to change. For all products Palmer Hamilton reserves the right to make adjustments due to changing market conditions, product discontinuation, legislative requirements or other circumstances.

Visit our website to see the complete family of Palmer Hamilton products  
800-788-1028 | [www.palmerhamilton.com](http://www.palmerhamilton.com)

OF-B6XPP Spec 0124

