

SPEC SHEET OF-T46SQP
46" EXPANDED SQUARE TABLE - portable mount

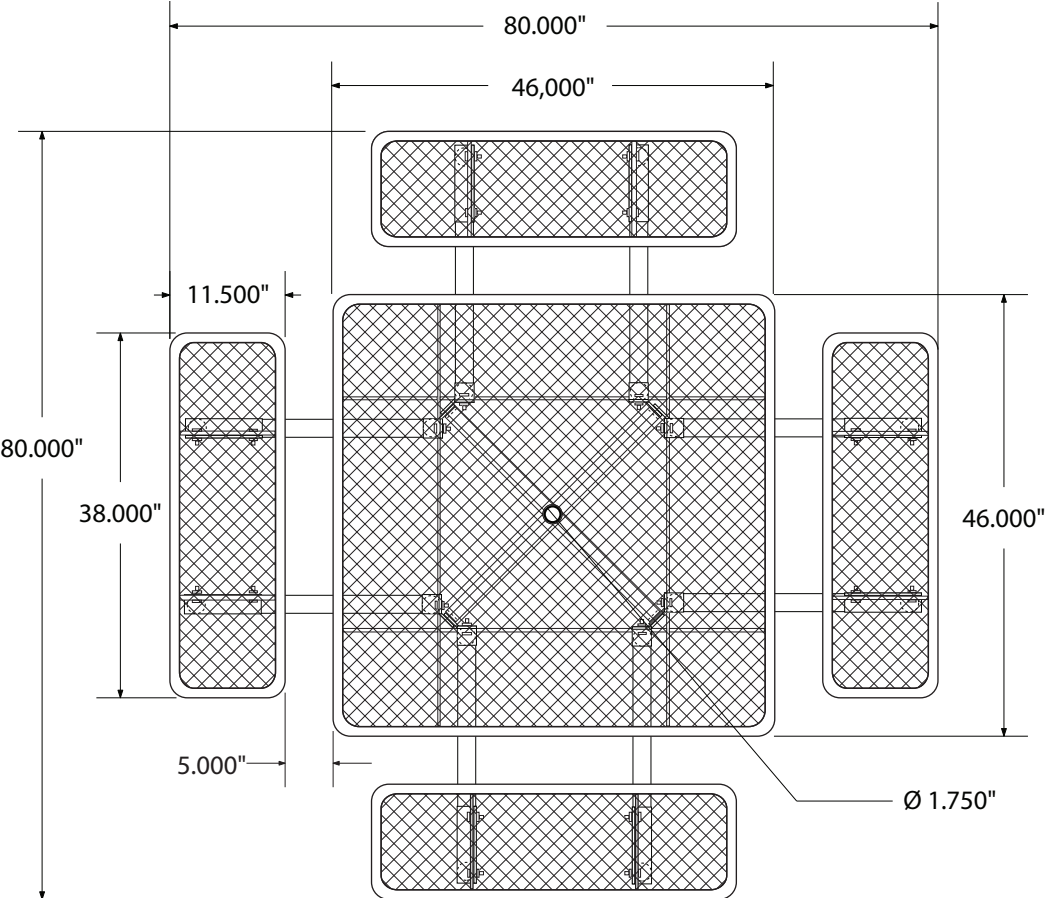

top view



side view

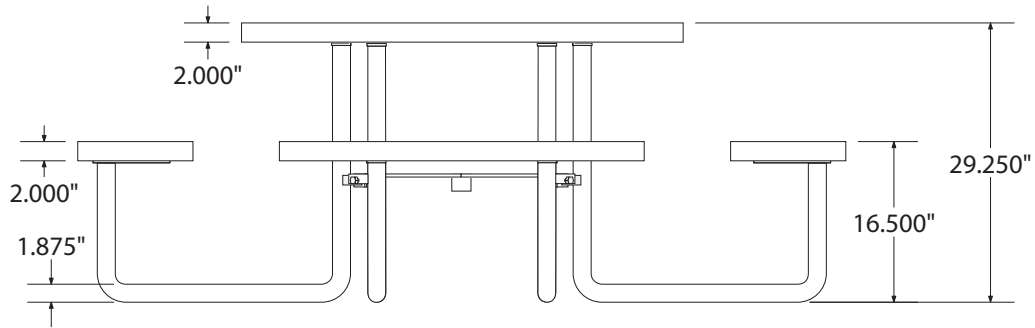

product finish

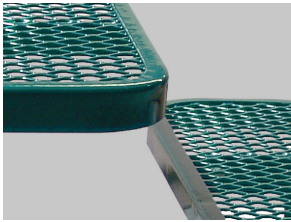

Coated Surfaces

- Thermoplastic coated
- Copolymer-based, environmentally safe
- Does not fade, crack, peel, or warp
- Applied at a thickness 25-30 mils.
- 5 year warranty on coating



Construction

- Seats and tops - 9 gauge steel
- 2" galvanized tubular steel understructure
- Black polyester powder coat on understructure
- Galvanized hardware

mounting styles

P = Portable; no mount

SM = Surface Mount;
concrete anchors through tabs
welded to legs

IG = In-Ground; J-rods set in
concrete through tabs welded
to legs.

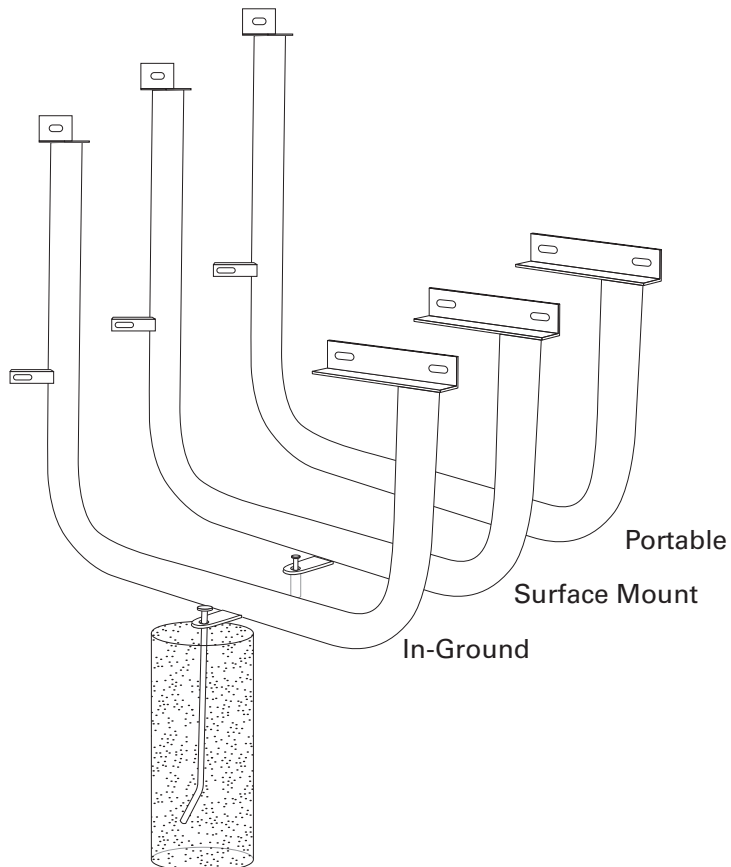

All design specifics subject to change. For all products Palmer Hamilton reserves the right to make adjustments due to changing market conditions, product discontinuation, legislative requirements or other circumstances.

Visit our website to see the complete family of Palmer Hamilton products
800-788-1028 | www.palmerhamilton.com

OF-T46SQP Spec 0124

