

**SPEC SHEET OF-T6XPP**  
**6' EXPANDED PICNIC TABLE - portable mount**

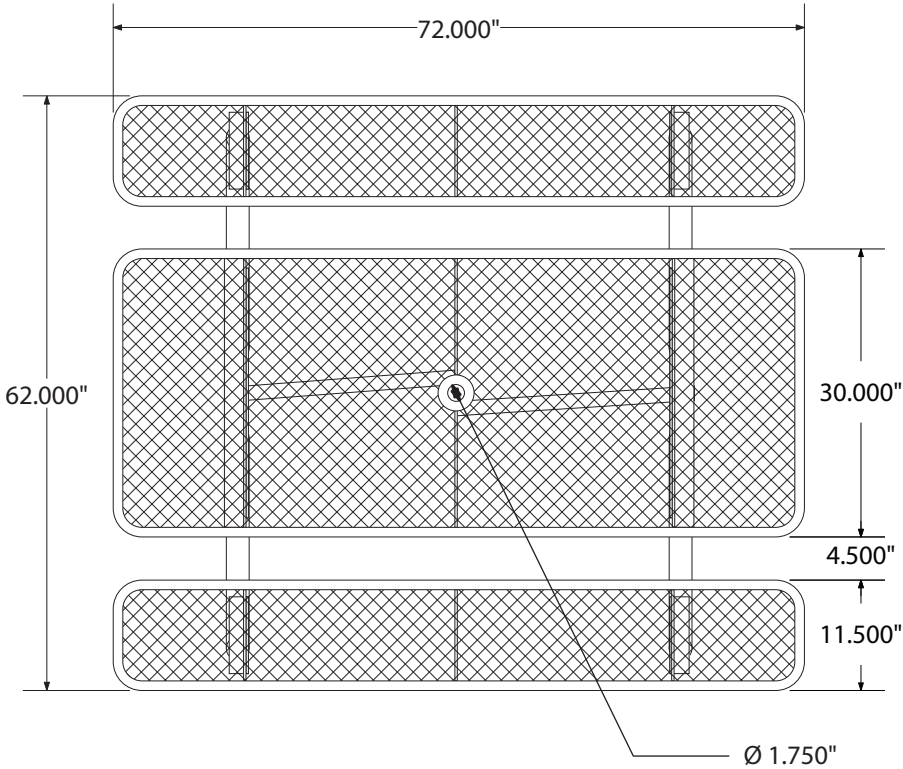

top view



front view

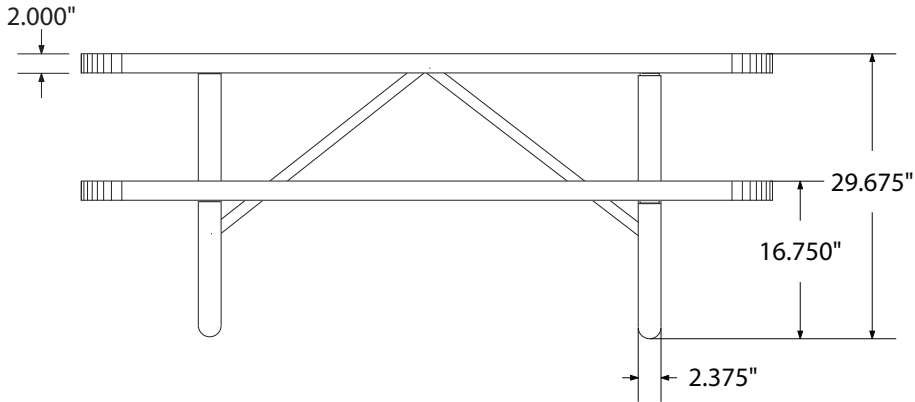

## side view

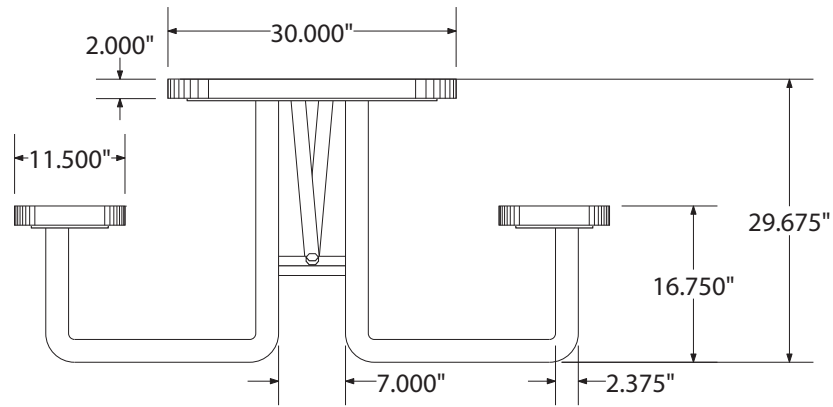

## product finish

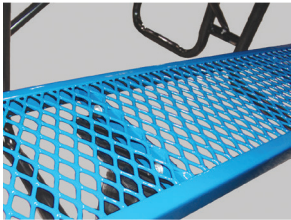

### Coated Surfaces

- Thermoplastic coated
- Copolymer-based, environmentally safe
- Does not fade, crack, peel, or warp
- Applied at a thickness 25-30 mils
- 5 year warranty on coating



### Construction

- Seats and tops - 9 gauge steel
- 2 $\frac{3}{8}$ " galvanized tubular steel understructure
- Black polyester powder coat on understructure
- Galvanized hardware

## mounting styles

P = Portable: no mount

SM = Surface Mount:  
concrete anchors through  
tabs welded to legs

IG = In-Ground: either ex-  
tended legs for embedding  
in concrete or J-rods set in  
concrete through tabs weld-  
ed to legs.

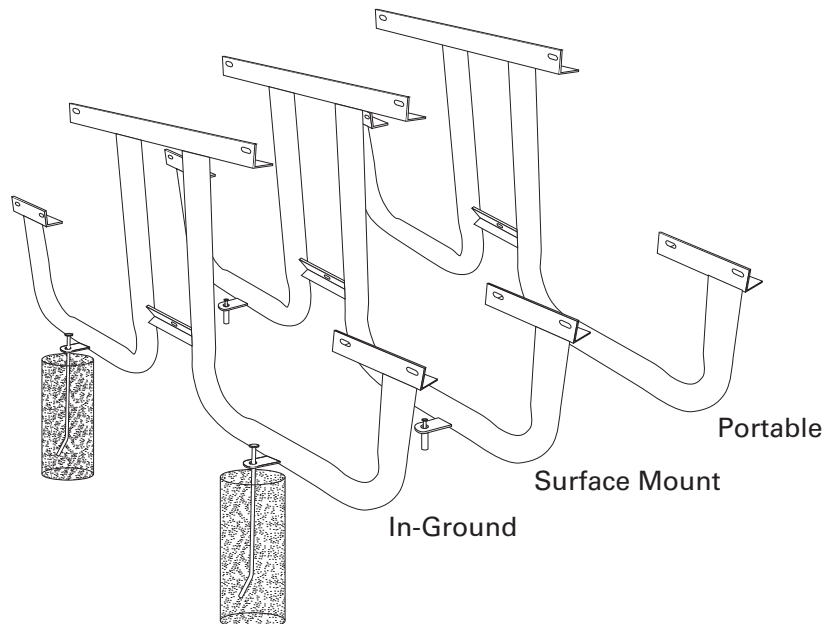

All design specifics subject to change. For all products Palmer Hamilton reserves the right to make adjustments due to changing market conditions, product discontinuation, legislative requirements or other circumstances.

Visit our website to see the complete family of Palmer Hamilton products  
800-788-1028 | [www.palmerhamilton.com](http://www.palmerhamilton.com)

OF-T6XPP Spec 0124

