

ASSEMBLY SHEET OF-T8XPP-ADA/OF-T8XPP-ADA-PERF 8' ADA PICNIC TABLE

parts

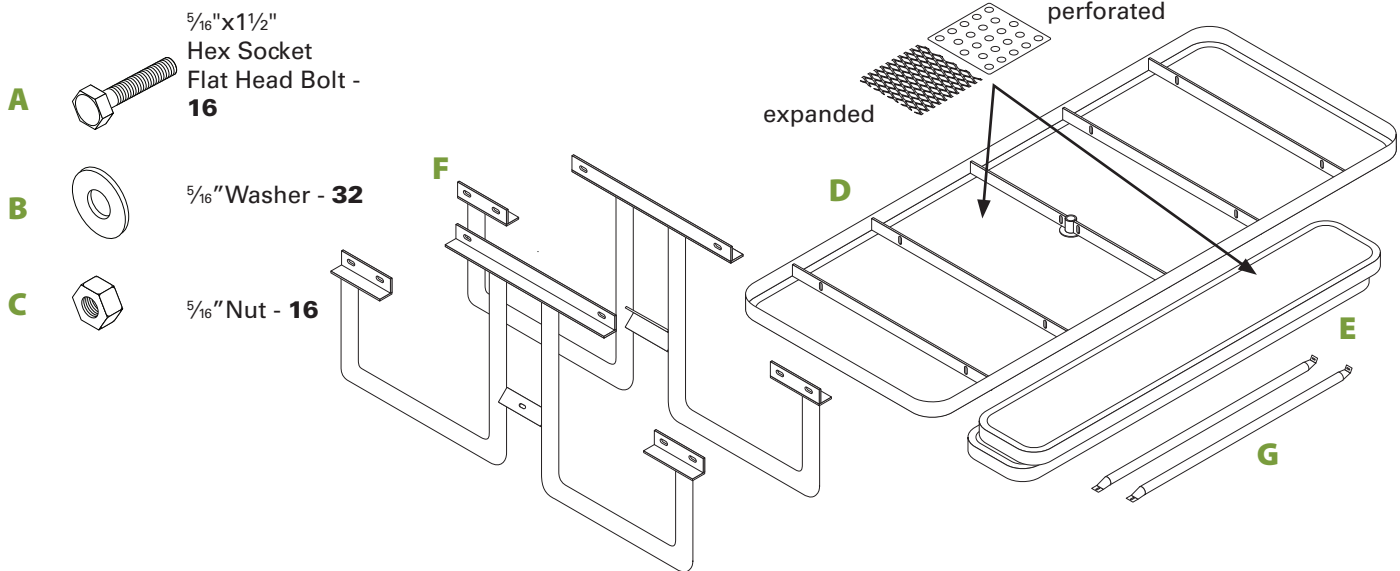

Note: Assembly for all 8 ft. ADA picnic tables [expanded and perforated] follow the same assembly details.

tools needed

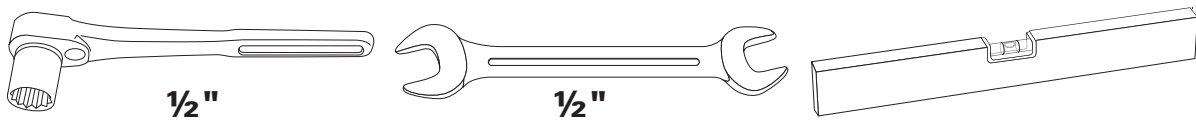

Note: Finger tighten all hardware until parts are adjusted before tightening with tools.

assembly - attach the legs to the tabletop

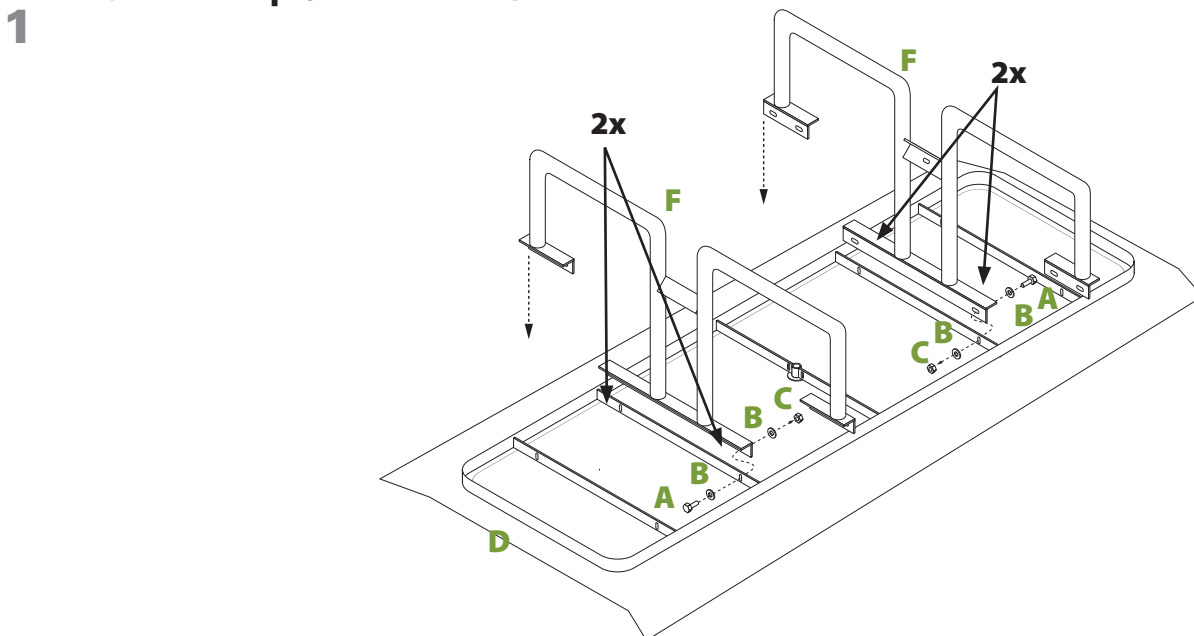

Note: Place top of table upside down on packaging box to protect bench surface when working on the ground.

assembly - attach the braces to the legs and tabletop

2

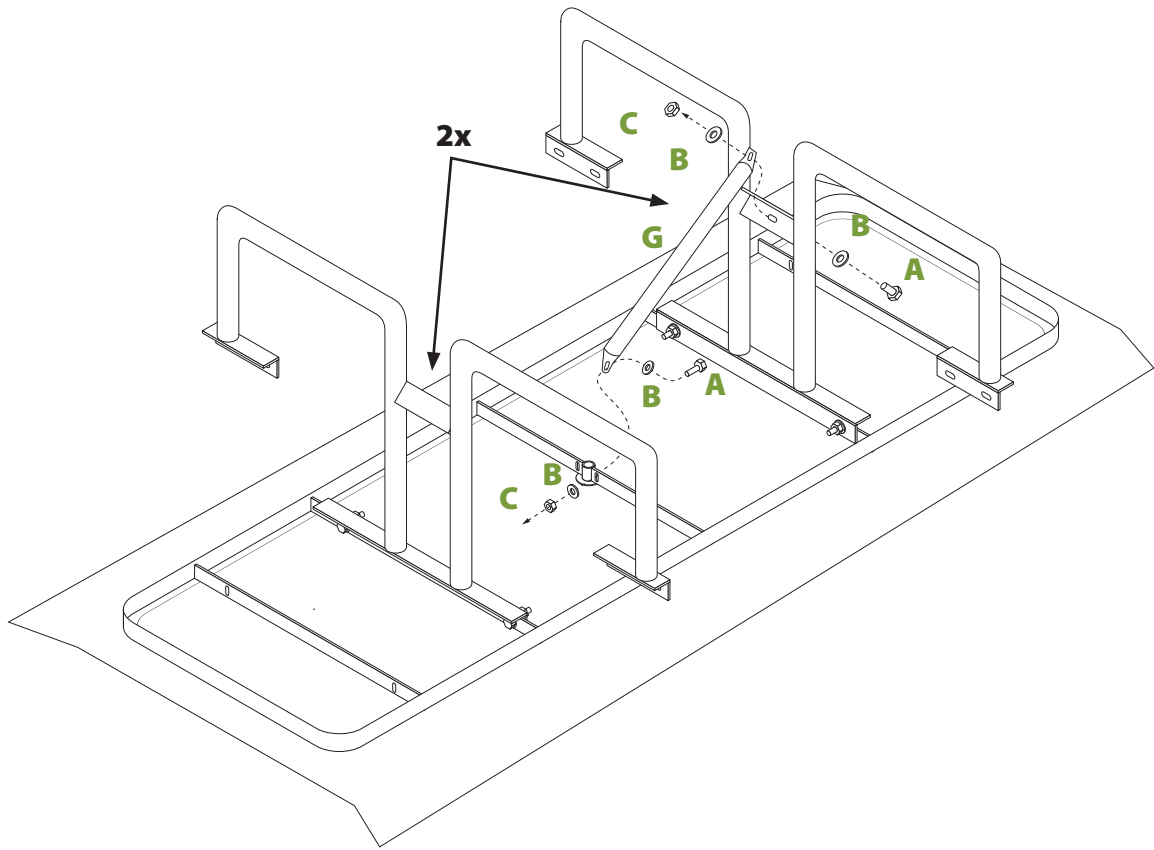

assembly - attach the seats to the legs

3

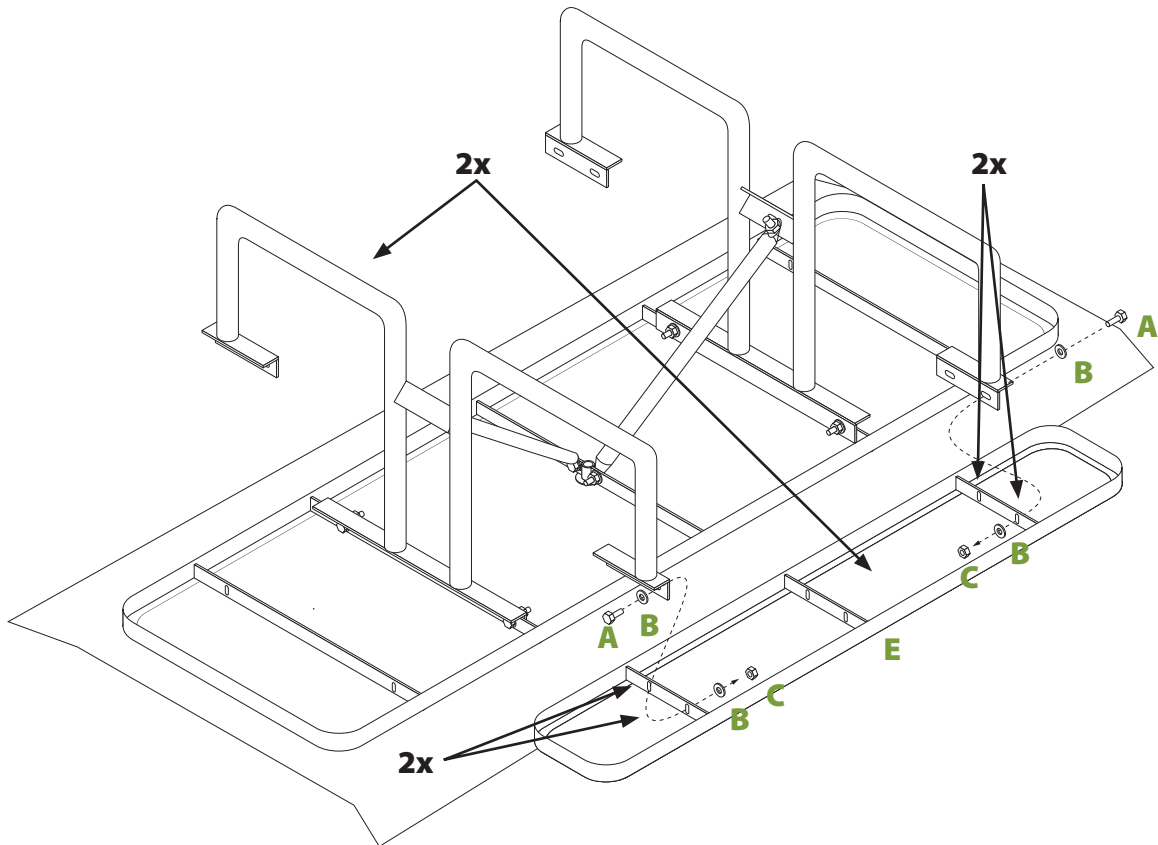

turn table to be right side up

4

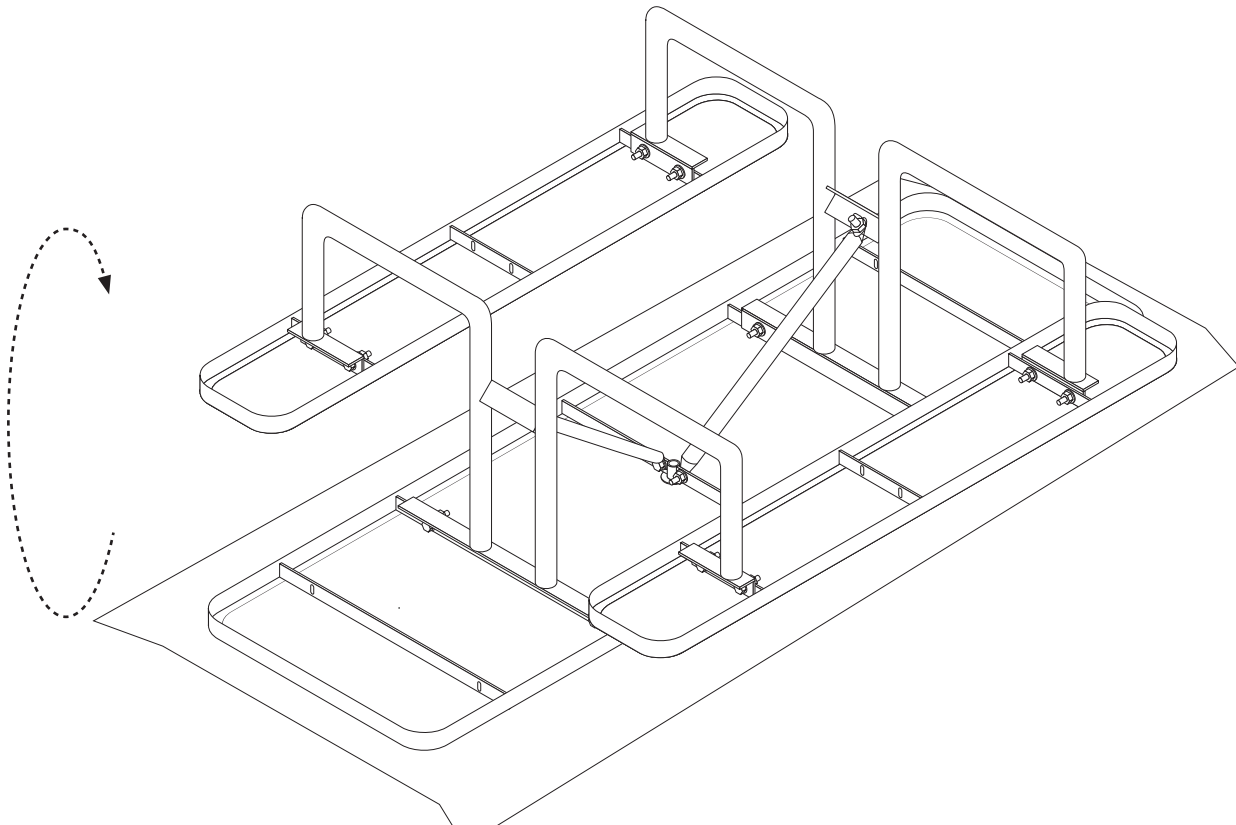

Note: The table may be turned to an upright position with the help of 4-6 adults

final adjustment with level and tools

5

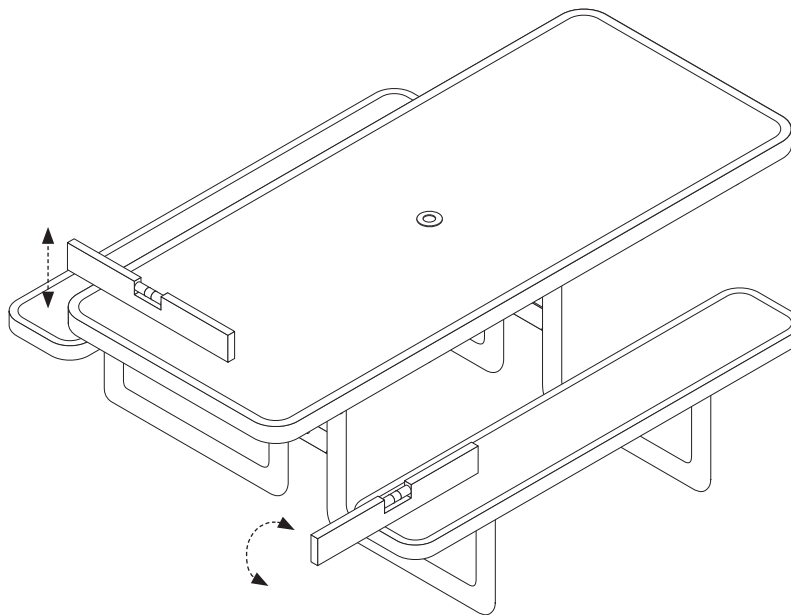

Note: Once the table is assembled and the top and seats made level, all hardware should be tightened with tools to 13 lbs-ft.

All design specifics subject to change. For all products Palmer Hamilton reserves the right to make adjustments due to changing market conditions, product discontinuation, legislative requirements or other circumstances.

Visit our website to see the complete family of Palmer Hamilton products
800-788-1028 | www.palmerhamilton.com

OF-T8XPP-ADA/OF-T8XPP-ADA-PERF Assembly 0124

