

SPEC SHEET OF-32SQEXP
32 GAL. EXPANDED SQUARE RECEPTACLE

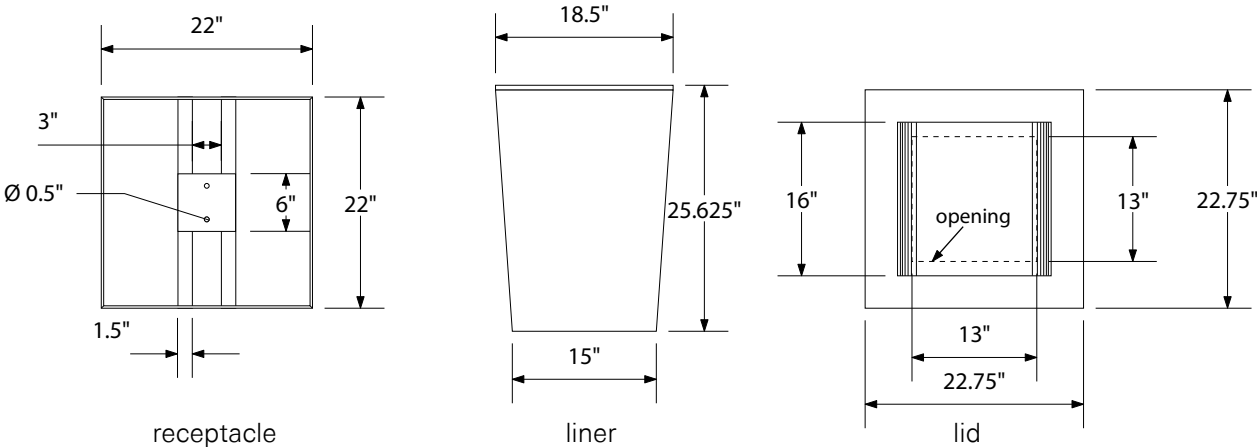

top view



front view

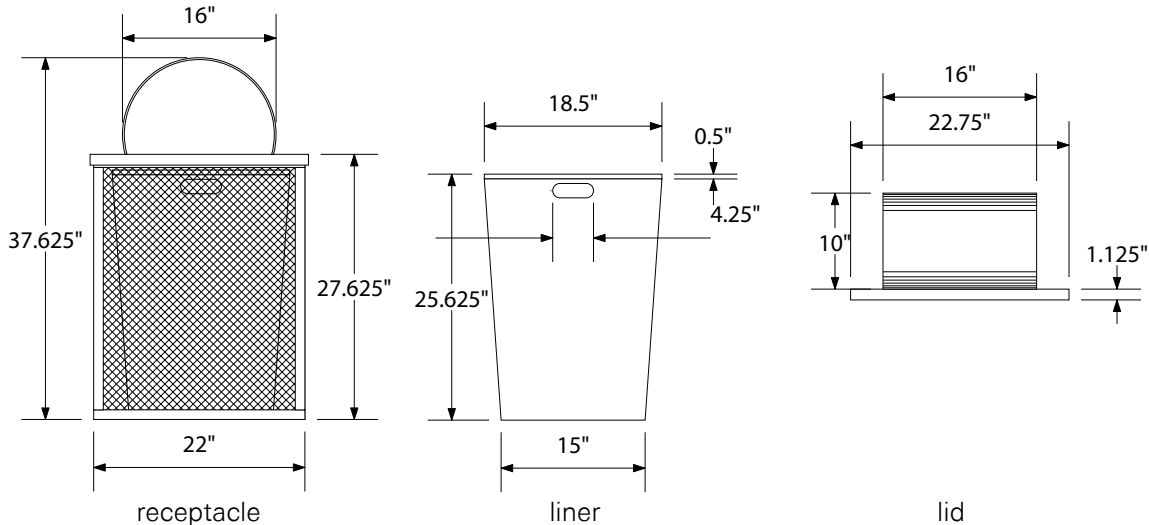

product finish



Coated Surfaces

- Thermoplastic coated
- Copolymer-based, environmentally safe
- Does not fade, crack, peel, or warp
- Applied at a thickness 25-30 mils
- 5 year warranty on coating



Construction

- Receptacle - 9 gauge steel expanded metal with 1/2" mild steel rod for rim/seam
- Liner - black polyethylene-plastic
- Lid - 11 gauge steel with thermoplastic coating

Weight

- 110 lbs.

mounting styles

P = Portable: no mount

SM = Surface Mount: concrete anchors through tabs welded to 6" center plate [1] or B100 6" above ground mount [2]

IG= In-Ground: bolts attach at 6" center plate to B200 receptacle mount embedded in concrete

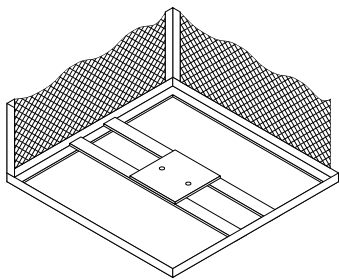

portable

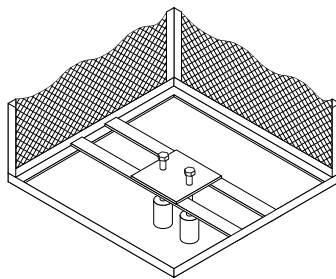

surface mount [1]

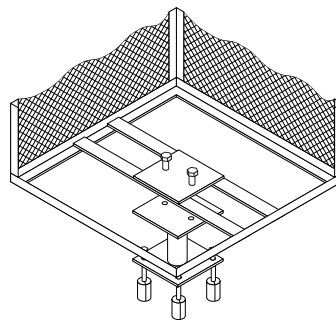

surface mount [2]

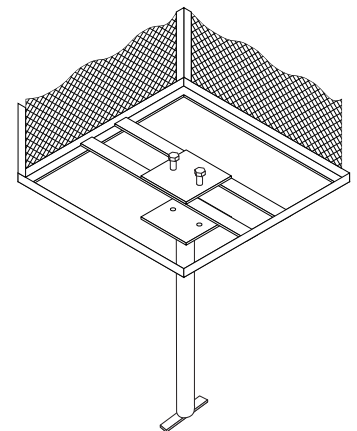

in-ground

All design specifics subject to change. For all products Palmer Hamilton reserves the right to make adjustments due to changing market conditions, product discontinuation, legislative requirements or other circumstances.

Visit our website to see the complete family of Palmer Hamilton products
800-788-1028 | www.palmerhamilton.com

70904

OF-32SQEXP Spec_0424

