

SPEC SHEET OF-HP6WB
6' HIGH POINT BENCH WITH BACK

photo

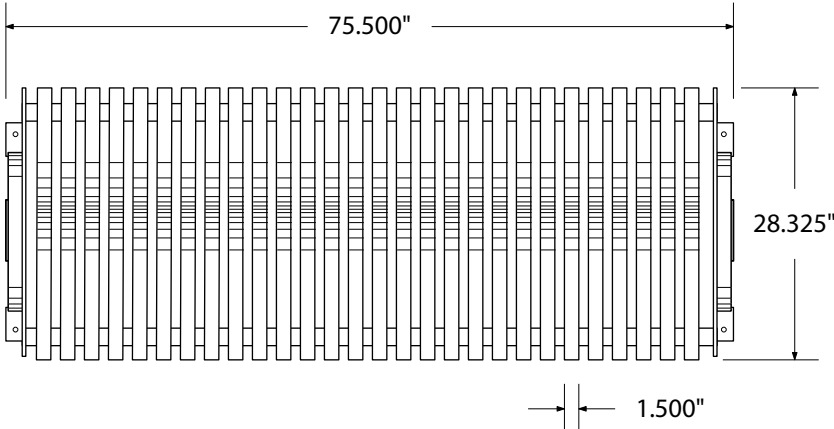

top view



front view

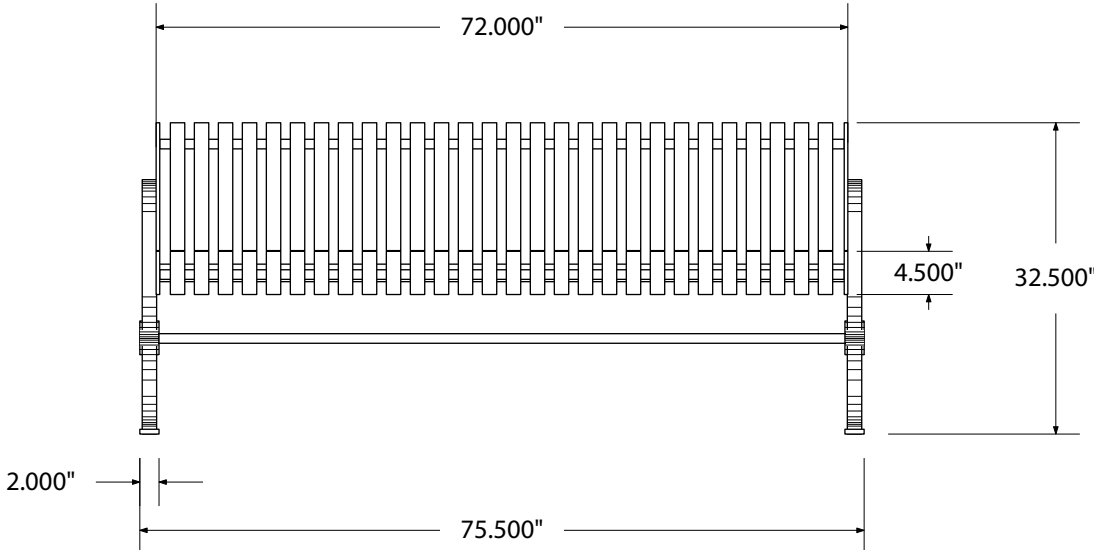

side view

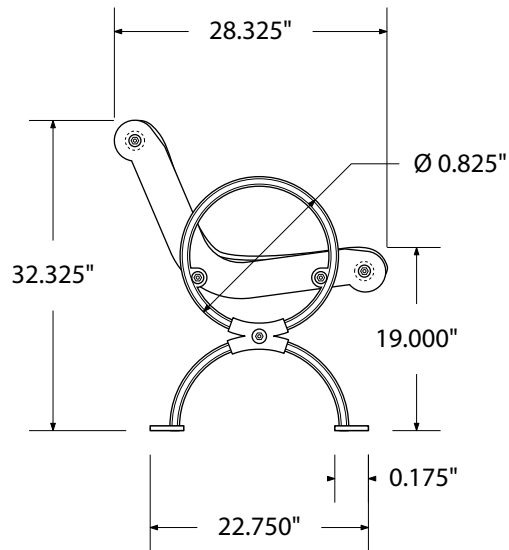

product details



Coated Surfaces

- Thermoplastic coated
- Copolymer-based, environmentally safe
- Does not fade, crack, peel warp
- Applied at a thickness of 25-30 mils.
- 5 Year warranty on coating

Construction

- 1½" Steel straps welded to tube braces
- 2" Schedule 40 tube braces
- 1" Schedule 40 pipe bottom brace
- Heavyweight cast-iron zinc-rich primed leg structure
- Nuts, washers and bolts - galvanized steel

Weight

- 245 lbs.

product details

P = Portable: no mount

SM = Surface Mount:
concrete anchors
through holes in feet

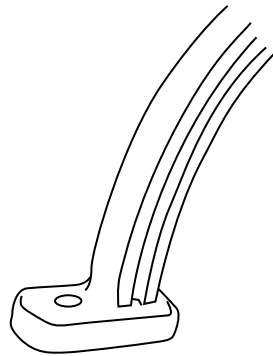

PORTABLE

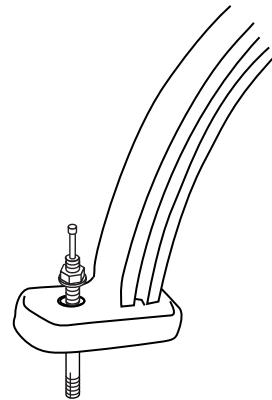

SURFACE MOUNT