

**OF-NG6 SPECIFICATIONS**  
**6' NORTHGATE BENCH**

**photo**

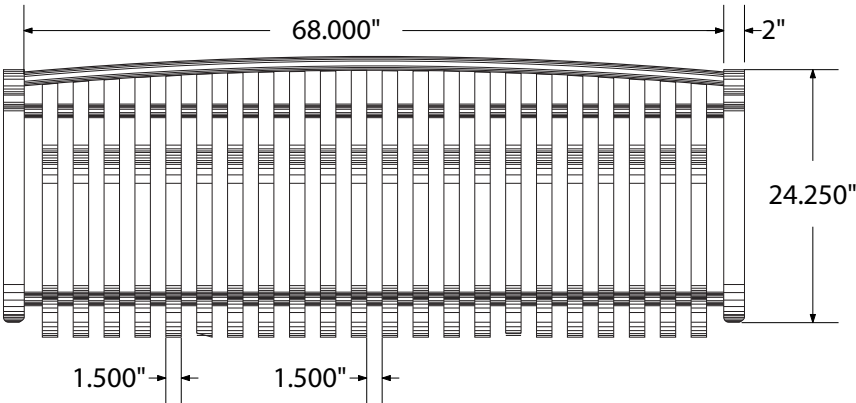

**top view**



**front view**

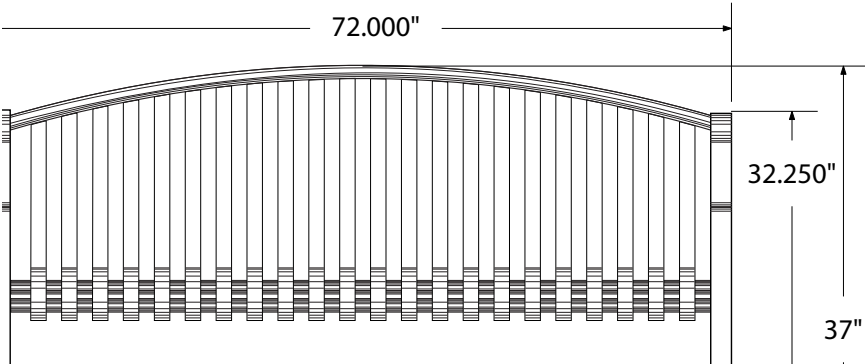

## side view

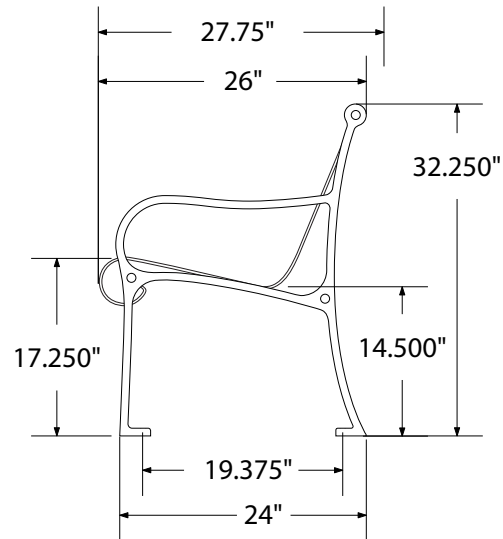

## product finish

### Coated Surfaces

- Thermoplastic coated Copolymer-based, environmentally safe
- Does not fade, crack, peel, or warp
- Applied at a thickness 25-30 mils
- 5 year warranty on coating

### Weight

- 260 lbs.

## mounting styles

**P** = Portable : no mount

**SM** = Surface Mount:  
concrete anchors  
through discs welded  
to legs

**IG** = In-Ground:  
J-rods set in concrete  
through discs welded  
to legs

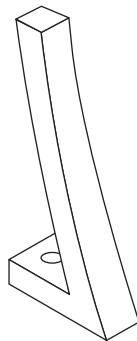

PORTABLE

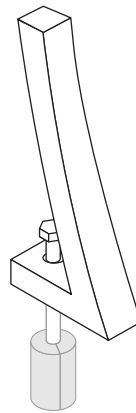

SURFACE MOUNT

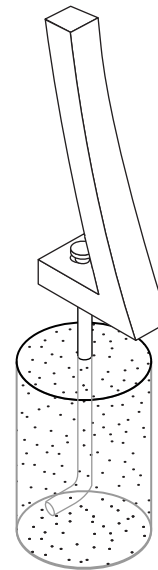

IN-GROUND

All design specifics subject to change. For all products Palmer Hamilton reserves the right to make adjustments due to changing market conditions, product discontinuation, legislative requirements or other circumstances.

Visit our website to see the complete family of Palmer Hamilton products  
800-788-1028 | [www.palmerhamilton.com](http://www.palmerhamilton.com)