

OF-RF32D-LNSML SPECIFICATIONS
32 GAL. DIAMOND RECEPTACLE WITH LINER AND SPUN METAL LID

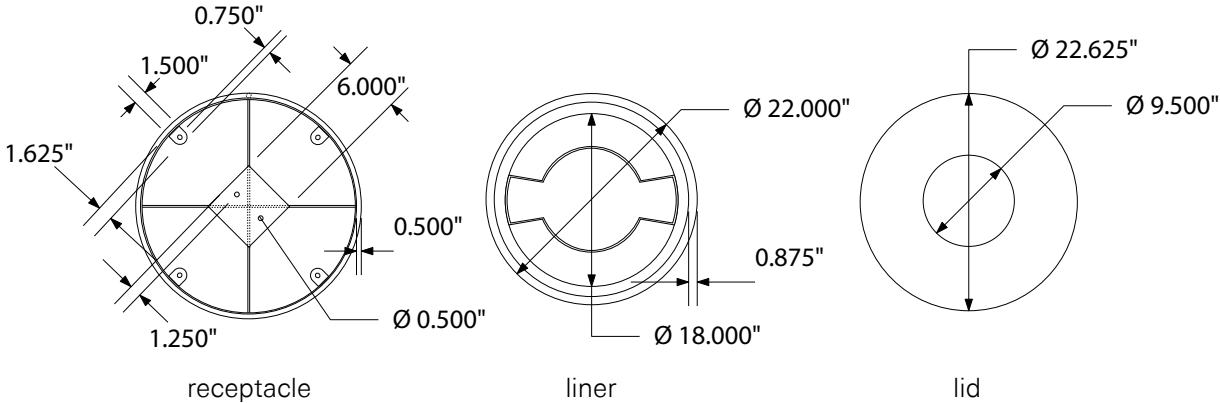

top view



front view

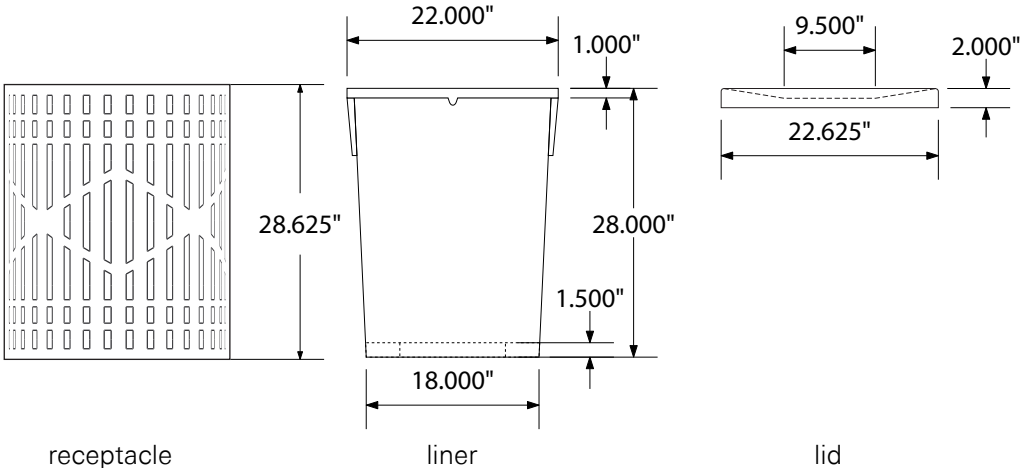

product finish



Coated Surfaces

- Thermoplastic coated
- Copolymer-based, environmentally safe
- Does not fade, crack, peel, or warp
- Applied at a thickness 25-30 mils
- 5 year warranty on coating



Construction

- Receptacle - 11 gauge steel with thermoplastic coating
- Liner - black polyethylene-plastic
- Lid - 11 gauge steel with thermoplastic coating

Weight

- 105 lbs.

mounting styles

P = Portable: no mount

SM = Surface Mount: concrete anchors through tabs welded to rims [1], or at 6" center plate to B100 above ground mount [2]

IG = In-Ground: bolts attach at 6" center plate to B200 receptacle mount embedded in concrete

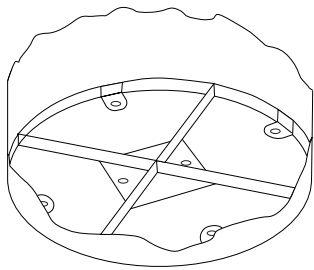

Portable

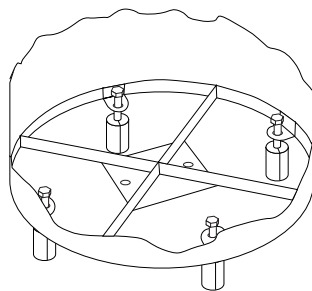

Surface Mount [1]
[anchors]

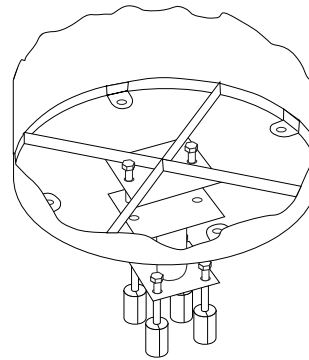

Surface Mount [2]
[B-100 6" mount]

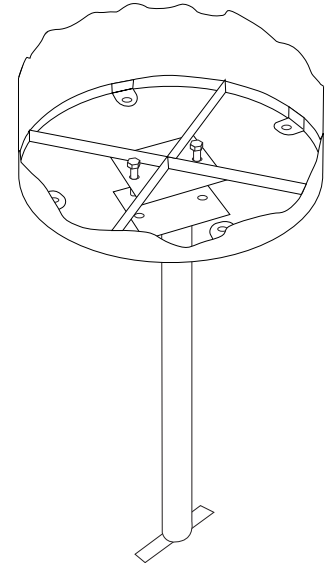

In-Ground
[B-200 mount]

All design specifics subject to change. For all products Palmer Hamilton reserves the right to make adjustments due to changing market conditions, product discontinuation, legislative requirements or other circumstances.

Visit our website to see the complete family of Palmer Hamilton products
800-788-1028 | www.palmerhamilton.com

70906

OF-RF32D-LNSML spec 0524

