

OF-SQ46P SPECIFICATIONS
46" SINGLE POST EXPANDED METAL SQUARE TABLE

photo

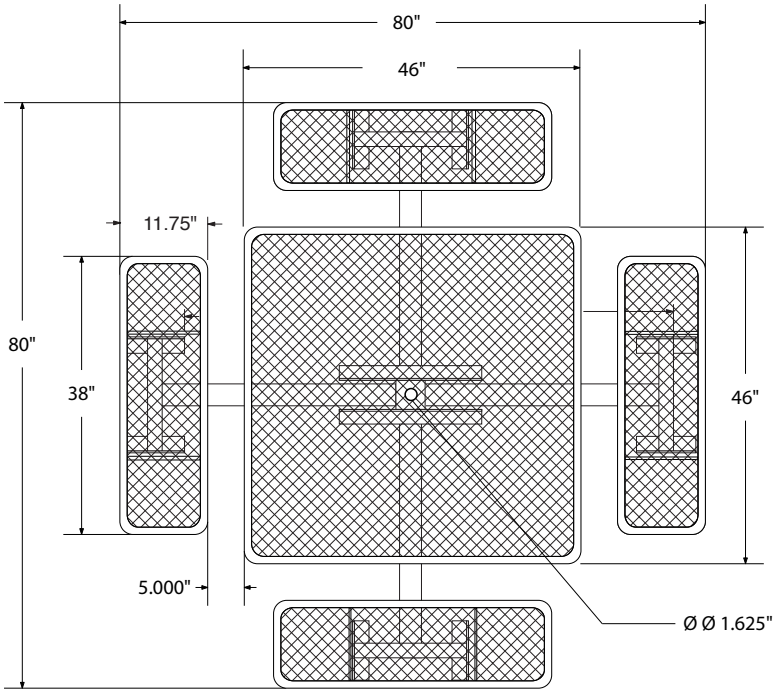

top view



TOP TABLE VIEW

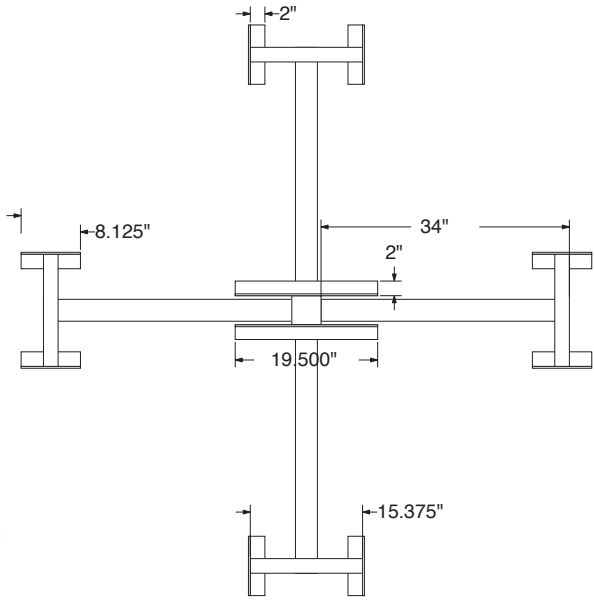

TOP STRUCTURE VIEW

side view

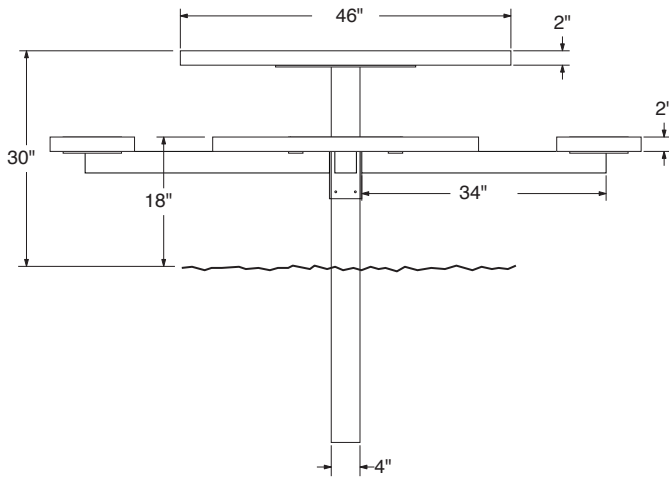

SIDE TABLE VIEW

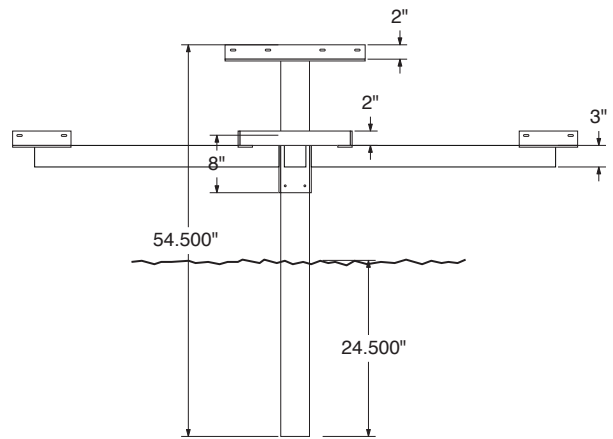

SIDE STRUCTURE VIEW

product finish

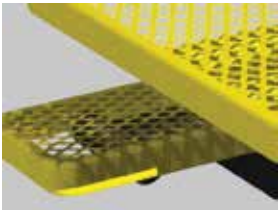

Coated Surfaces

- Thermoplastic coated Copolymer-based, environmentally safe
- Does not fade, crack, peel, or warp
- Applied at a thickness 25-30 mils
- 5 year warranty on coating

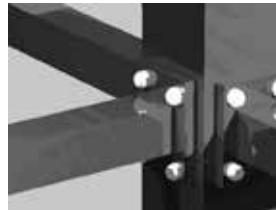

Construction

- Seats and tops - 9 gauge steel
- 3" & 4" tubular understructure
- Understructure - galvanized steel
- Understructure finish - black polyester powder coated
- Nuts, washers and bolts - galvanized steel

Weight

- 265 lbs.

mounting styles

IG= In-Ground:
Single post

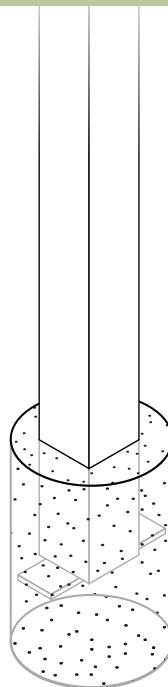

All design specifics subject to change. For all products Palmer Hamilton reserves the right to make adjustments due to changing market conditions, product discontinuation, legislative requirements or other circumstances.

Visit our website to see the complete family of Palmer Hamilton products
800-788-1028 | www.palmerhamilton.com

70942

OF-SQ46P spec 0624

