

OF-T46SQ SPECIFICATIONS
46" EXPANDED SQUARE TABLE

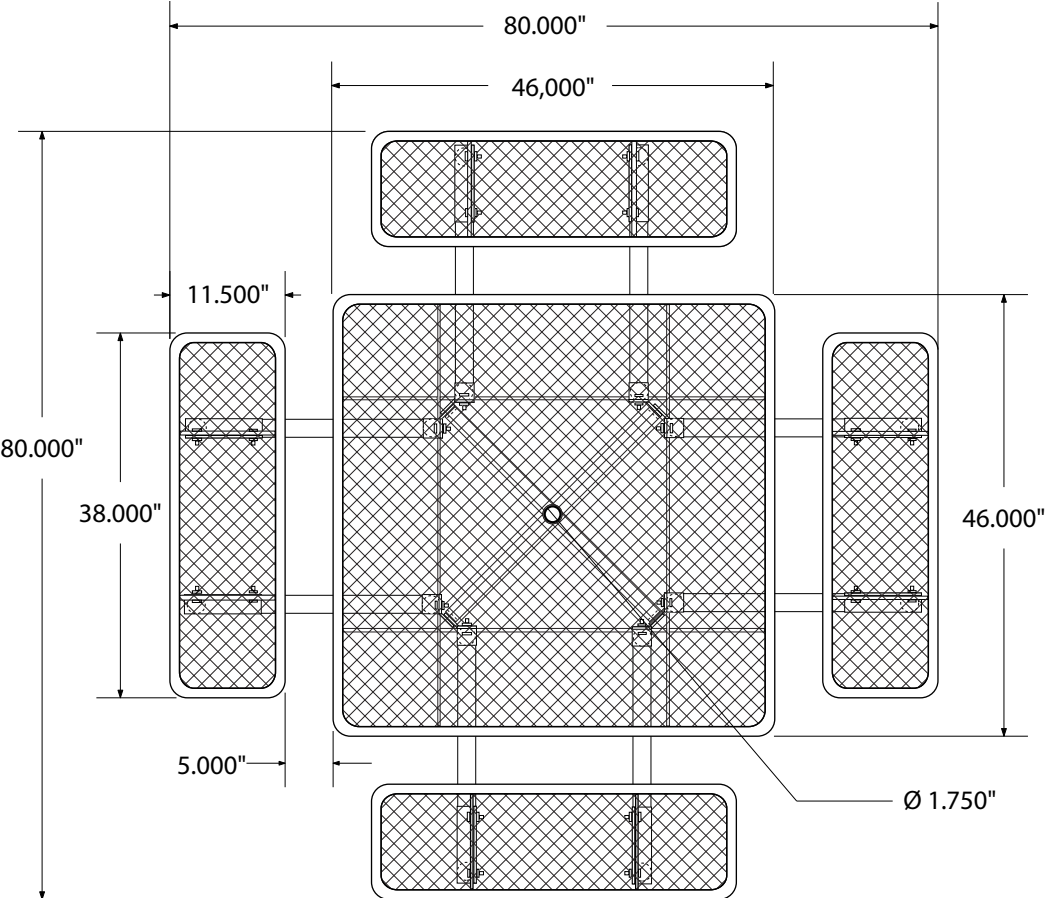

top view



side view

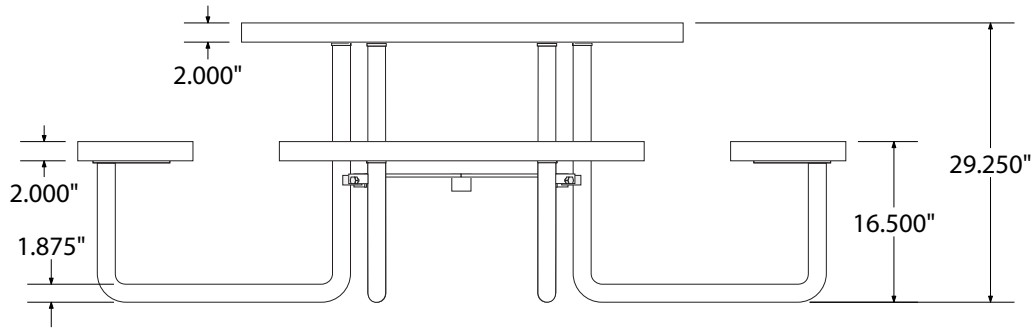

product finish

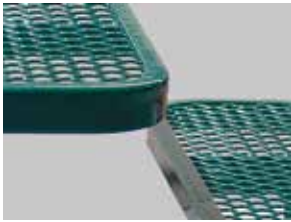

Coated Surfaces

- Thermoplastic coated
- Copolymer-based, environmentally safe
- Does not fade, crack, peel, or warp
- Applied at a thickness 25-30 mils
- 5 year warranty on coating



Construction

- Seats and tops - 9 gauge steel
- 2" galvanized tubular steel understructure
- Black polyester powder coat on understructure
- Galvanized hardware

Weight

- 275 lbs.

mounting styles

P = Portable: no mount

SM = Surface Mount:
concrete anchors through tabs
welded to legs

IG = In-Ground: J-rods set in
concrete through tabs welded
to legs.

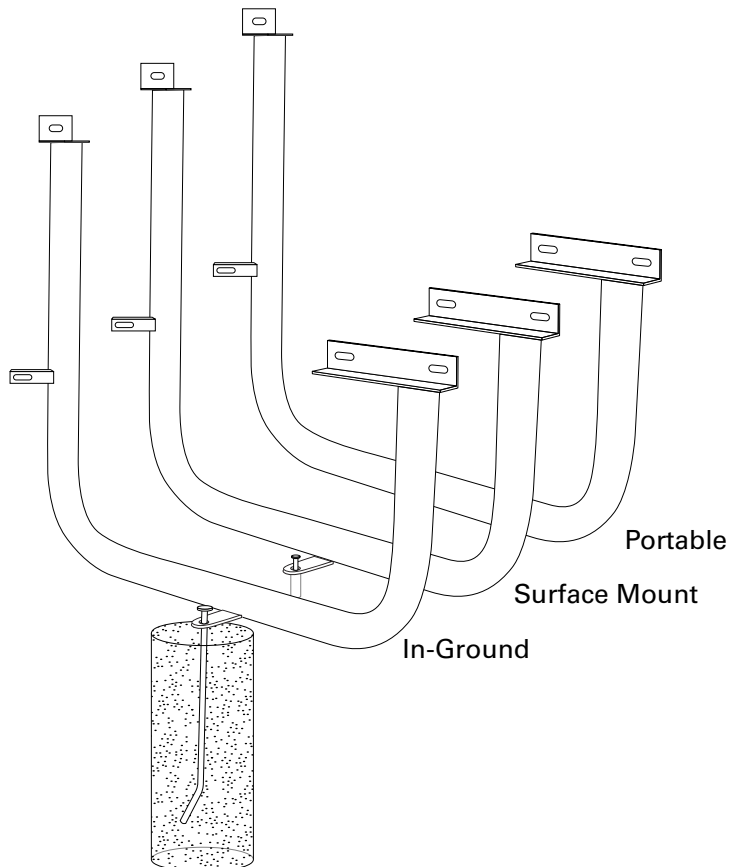

All design specifics subject to change. For all products Palmer Hamilton reserves the right to make adjustments due to changing market conditions, product discontinuation, legislative requirements or other circumstances.

Visit our website to see the complete family of Palmer Hamilton products
800-788-1028 | www.palmerhamilton.com

70914

OF-T46SQ spec 0524

