

OF-T6XP SPECIFICATIONS
6' EXPANDED PICNIC TABLE

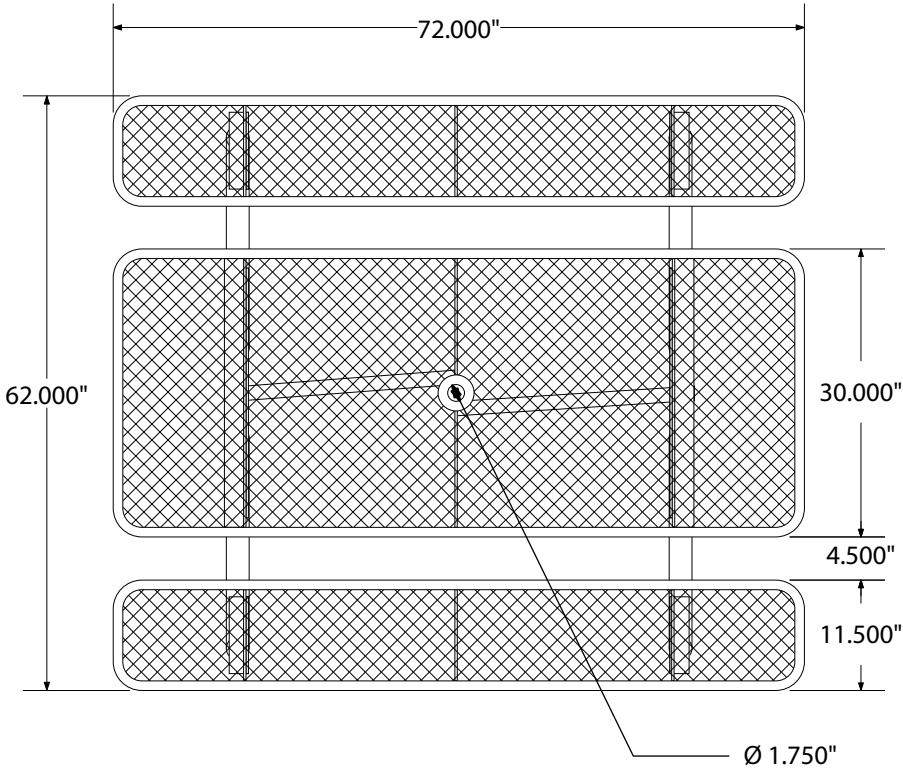

top view



front view

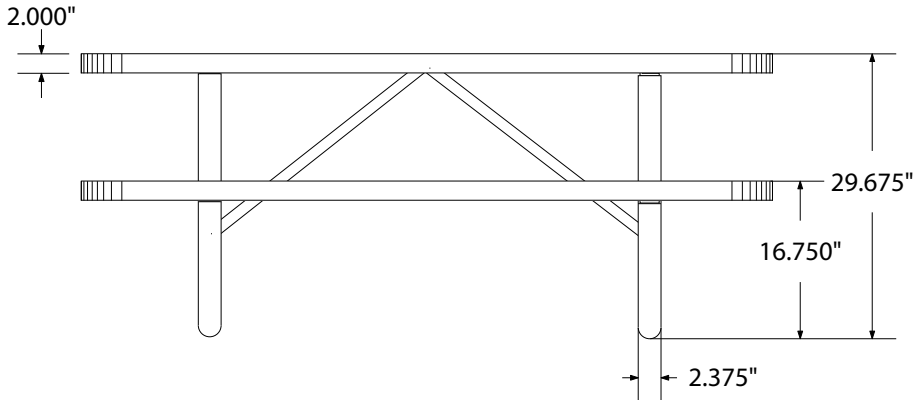

side view

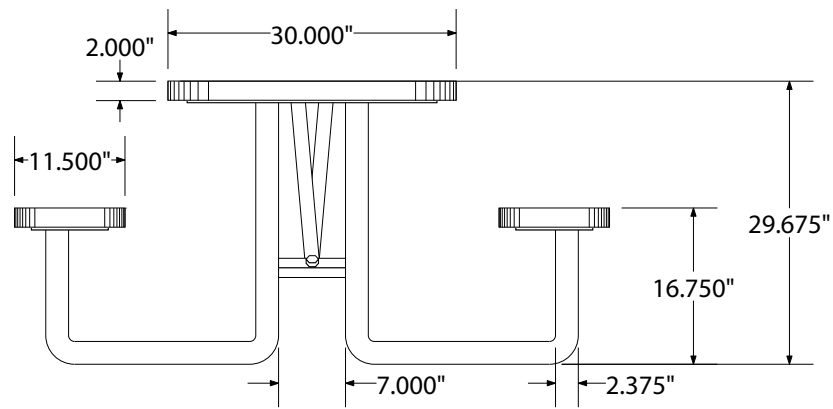

product finish

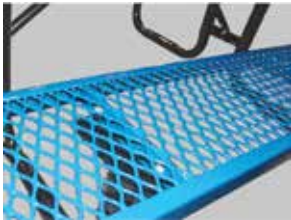

Coated Surfaces

- Thermoplastic coated
- Copolymer-based, environmentally safe
- Does not fade, crack, peel, or warp
- Applied at a thickness 25-30 mils
- 5 year warranty on coating



Construction

- Seats and tops - 9 gauge steel
- 2³/₈" galvanized tubular steel understructure
- Black polyester powder coat on understructure
- Galvanized hardware

Weight

- 220 lbs.

mounting styles

P = Portable: no mount

SM = Surface Mount:
concrete anchors through
tabs welded to legs

IG = In-Ground: either ex-
tended legs for embedding
in concrete or J-rods set in
concrete through tabs weld-
ed to legs.

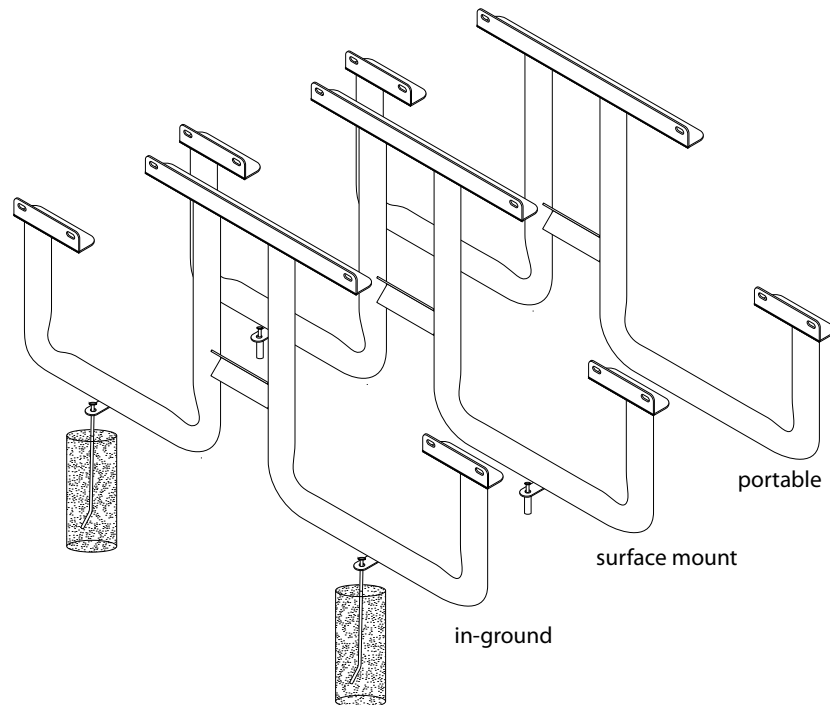

All design specifics subject to change. For all products Palmer Hamilton reserves the right to make adjustments due to changing market conditions, product discontinuation, legislative requirements or other circumstances.

Visit our website to see the complete family of Palmer Hamilton products
800-788-1028 | www.palmerhamilton.com

70917

OF-T6XPP spec 0524

