

OF-T8XP SPECIFICATIONS
8' EXPANDED PICNIC TABLE

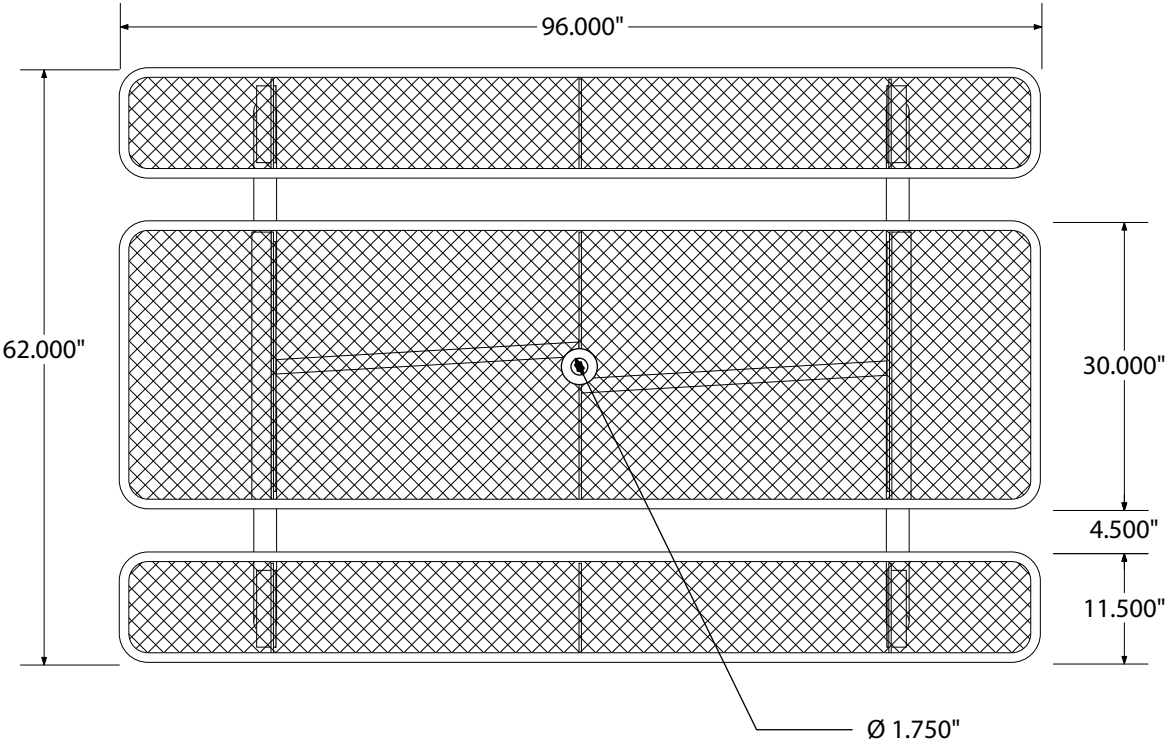

top view



front view

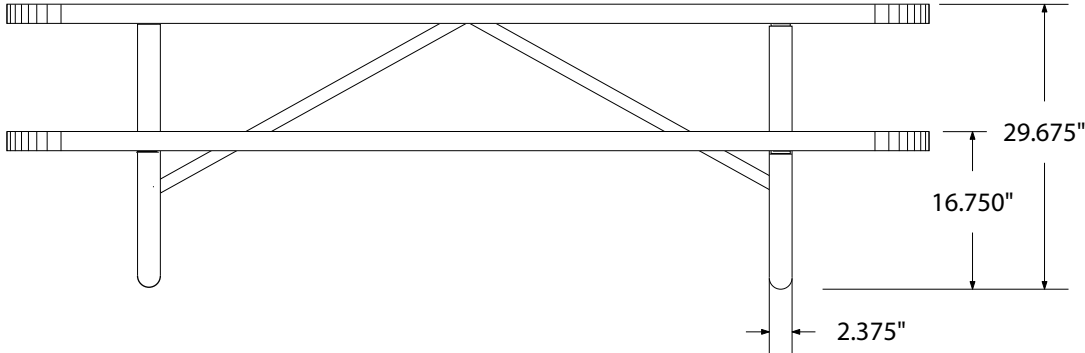

side view

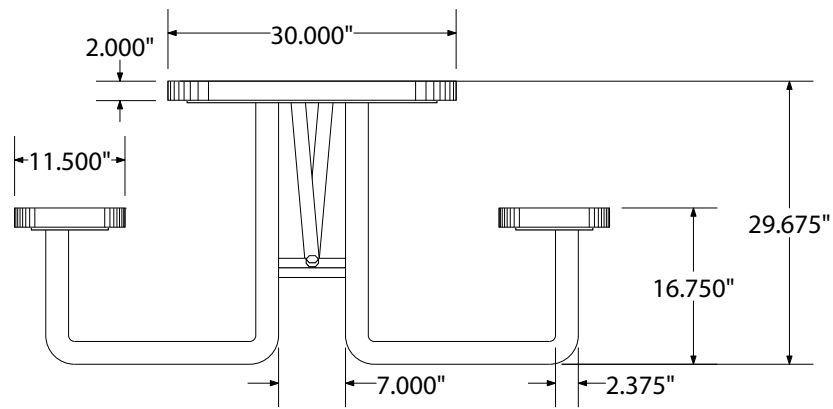

product finish

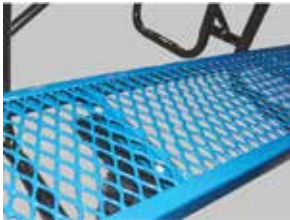

Coated Surfaces

- Thermoplastic coated
- Copolymer-based, environmentally safe
- Does not fade, crack, peel, or warp
- Applied at a thickness 25-30 mils
- 5 year warranty on coating



Construction

- Seats and tops - 9 gauge steel
- 2³/₈" galvanized tubular steel understructure
- Black polyester powder coat on understructure
- Galvanized hardware

Weight

- 380 lbs.

mounting styles

P = Portable: no mount

SM = Surface Mount:
concrete anchors through
tabs welded to legs

IG = In-Ground: either
extended legs for embed-
ding in concrete or J-rods
set in concrete through tabs
welded to legs.

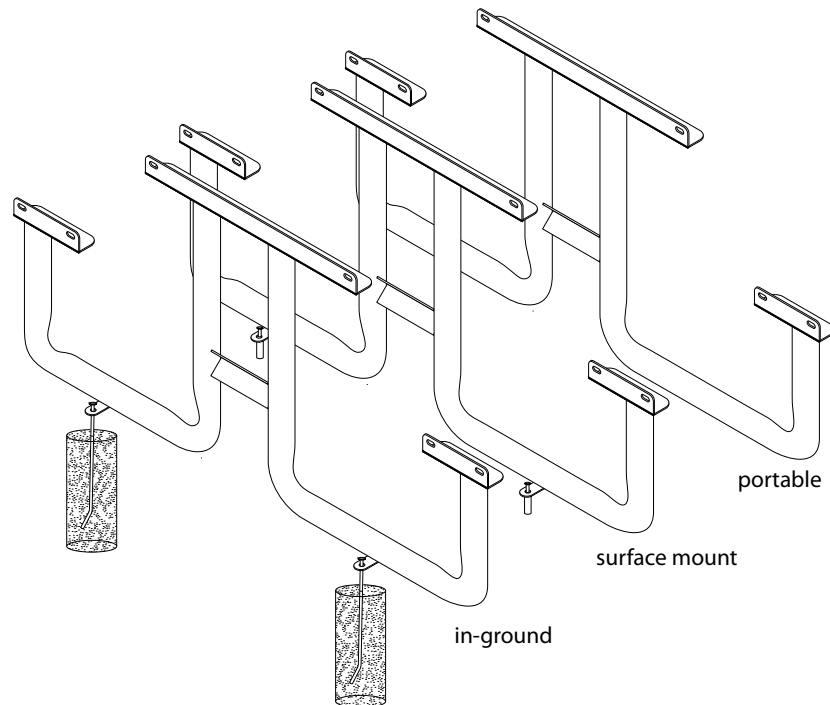

All design specifics subject to change. For all products Palmer Hamilton reserves the right to make adjustments due to changing market conditions, product discontinuation, legislative requirements or other circumstances.

Visit our website to see the complete family of Palmer Hamilton products
800-788-1028 | www.palmerhamilton.com

70919

OF-T8XP spec 0524

