

OF-36TABX40 SPECIFICATIONS
36" EXPANDED PEDESTAL TABLE, 40" HIGH

photo

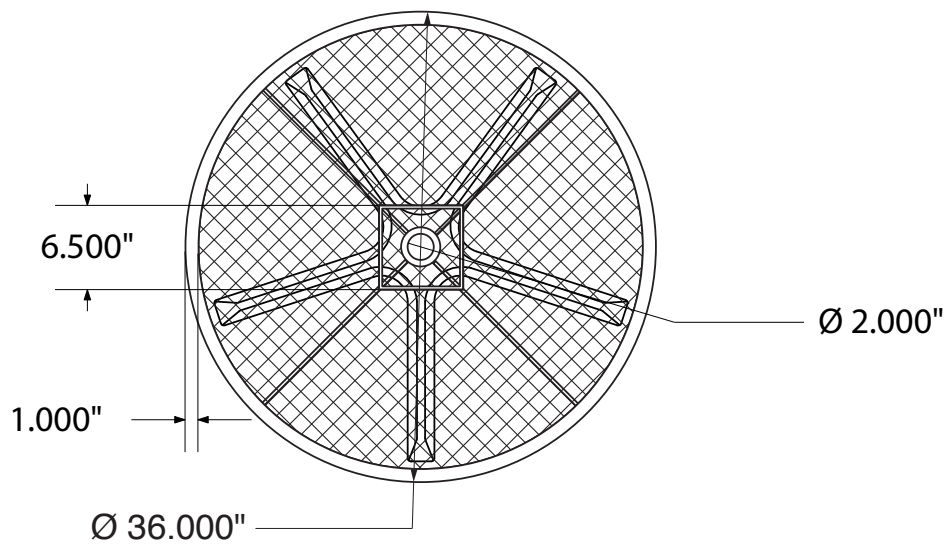

top view



side views

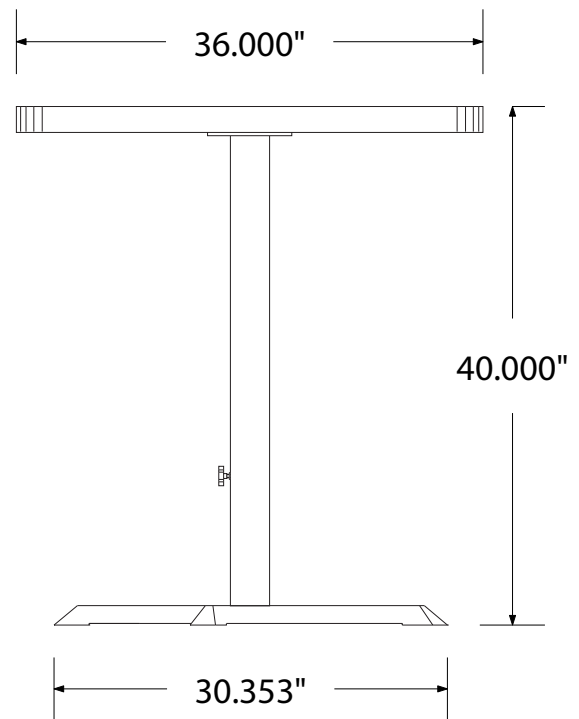
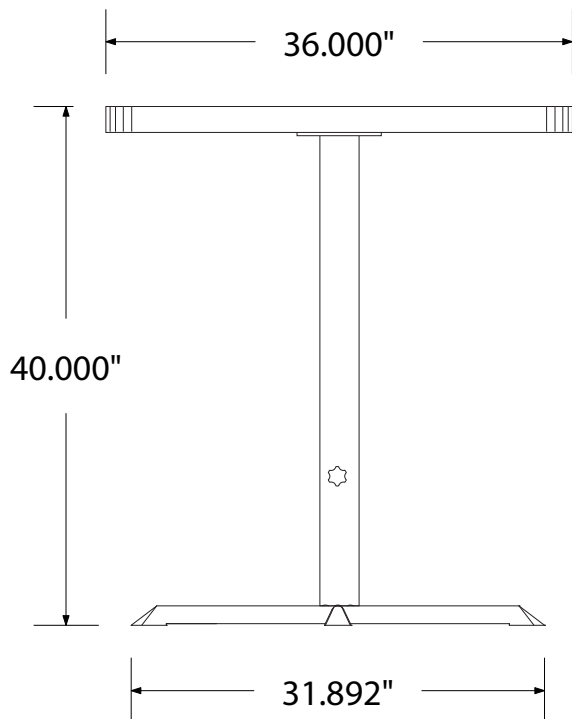

product finish



Coated Surfaces

- Thermoplastic coated Copolymer-based, environmentally safe
- Does not fade, crack, peel, or warp
- Applied at a thickness 25-30 mils
- 5 year warranty on coating



Construction

- Table tops - 9 gauge steel
- 3" Tubular steel support
- Cast iron base
- Nuts, washers and bolts - galvanized steel

Weight

- 80 lbs.

All design specifics subject to change. For all products Palmer Hamilton reserves the right to make adjustments due to changing market conditions, product discontinuation, legislative requirements or other circumstances.

Visit our website to see the complete family of Palmer Hamilton products
800-788-1028 | www.palmerhamilton.com

70947

OF-36TABX40 spec 0724

