

OF-SC32-SML SPECIFICATIONS
32 GAL. RING RECEPTACLE WITH SPUN METAL LID AND PLASTIC LINER

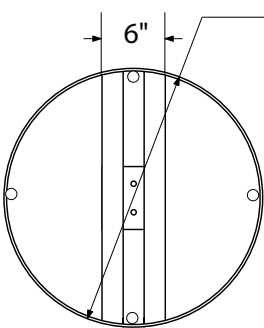

bottom / top view



receptacle

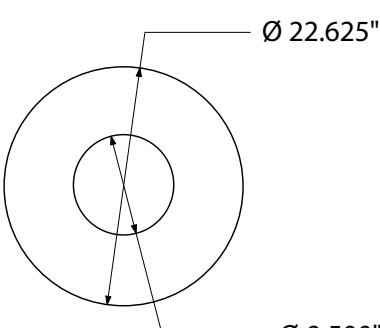

lid

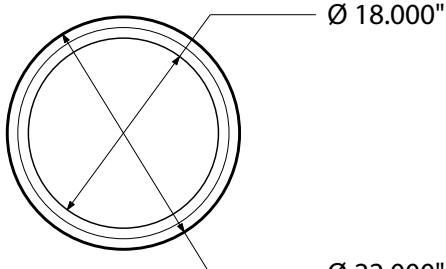

liner

front view

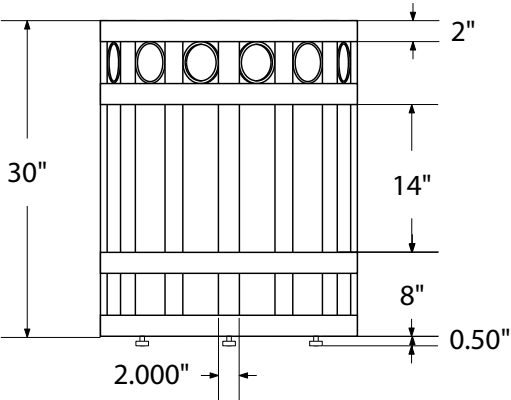

receptacle

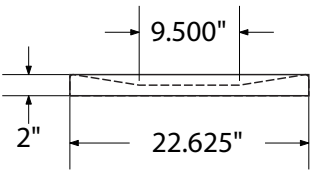

lid

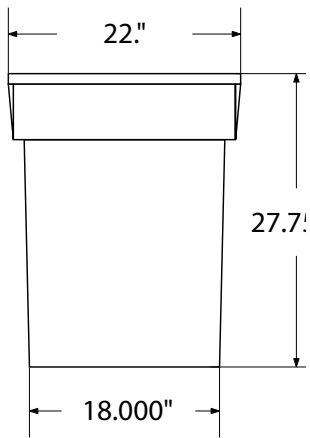

liner

product details



Coated Surfaces

- Thermoplastic coated
- Copolymer-based, environmentally safe
- Does not fade, crack, peel, or warp
- Applied at a thickness 25-30 mils
- 5 year warranty on coating

Weight

- 180 lbs.



Liner

- Black polyethylene plastic

Receptacle Construction

- 1/4" x 2" Steel straps
- 1 1/2" Steel tube lip
- 4 Leveler feet
- Surface mount plate for B100, B200 mounts (see below)

mounting styles

P = Portable :

No mount.

Surface Mount 1:

Concrete anchors through bottom plate.

Note: Levelers and bracket for portable mounting and Surface Mount Style 1 included. Other mounts are sold separately.

Surface Mount 2:

Bolts through bottom plate into B100 surface mount. B100 Mounted to concrete with anchors.

IG = In-Ground:

Bolts through bottom plate into B200 surface mount. B200 embedded in hole filled with concrete.

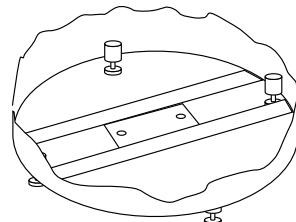

Portable

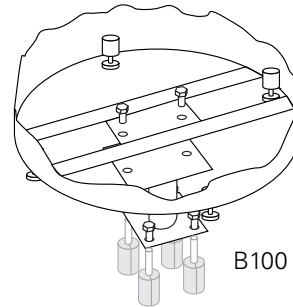

Surface Mount 2

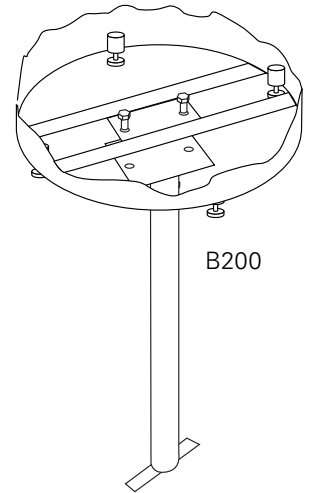

In-Ground

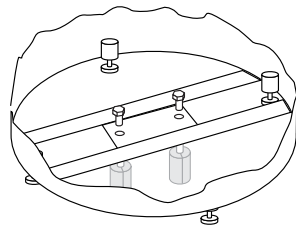

Surface Mount 1

All design specifics subject to change. For all products Palmer Hamilton reserves the right to make adjustments due to changing market conditions, product discontinuation, legislative requirements or other circumstances.

Visit our website to see the complete family of Palmer Hamilton products
800-788-1028 | www.palmerhamilton.com

70957

OF-SC32-SML Spec 0824

