



colors, graphics and
furniture selection

2025

New York City Board of Education

Palmer Hamilton has developed graphic packages representing the 5 New York City boroughs. Customize your cafeteria by selecting your colors and furniture styles that best fit your school spirit and space.

- M a n h a t t a n
- B r o o k l y n
- Q u e e n s
- t h e B r o n x
- S t a t e n I s l a n d

colors & graphics

Colors ^A

Select the colors your school would like to use in its graphics.

Select from our list or provide your logo color Pantone numbers. Our designers will use your colors as they determine the finishes for your furniture and develop the graphics.

Note: Due to limitations in the printing process, actual colors may appear slightly different.



Graphics Chose from **three** unique graphic color palettes.

1 Neutral Palette

The Neutral Palette works best for schools with multiple personalities, allowing a sophisticated backdrop for school pride.

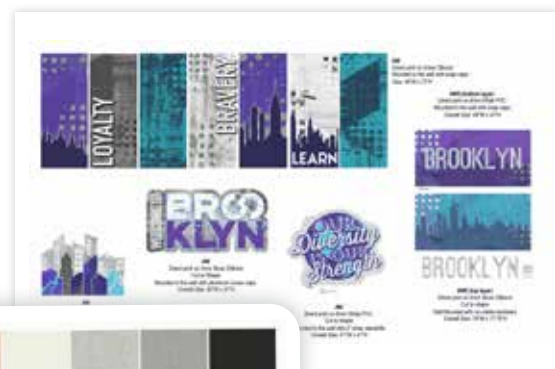

2 School Spirit Palette

This graphics package design will take your school colors choices (above right) and make them shine throughout the dining space.

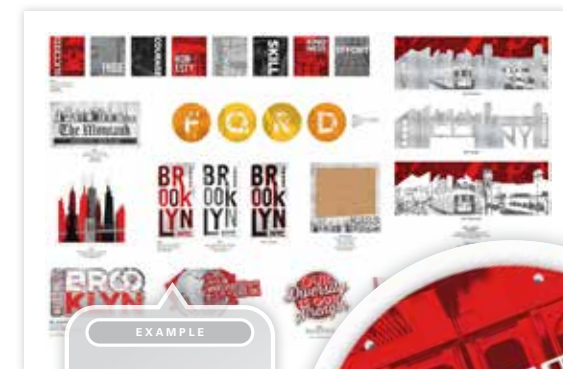

EXAMPLE

^A Your colors selected from the colors above "A".

 Candy Apple

 Black Bird

Your school graphics may look like this.



3 Vivid Palette

The "vivid" design style takes your school color choices and incorporates them to create bright, fun and vibrant graphics with coordinated seating.



mobile tables

furniture

palmer HAMILTON

OPTION SAMPLES:

Frames:
Black

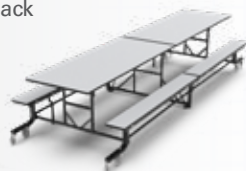

Laminates:
Match your school colors,
or stay neutral



Our designers will use your color selections to enhance your space.

Made in the USA

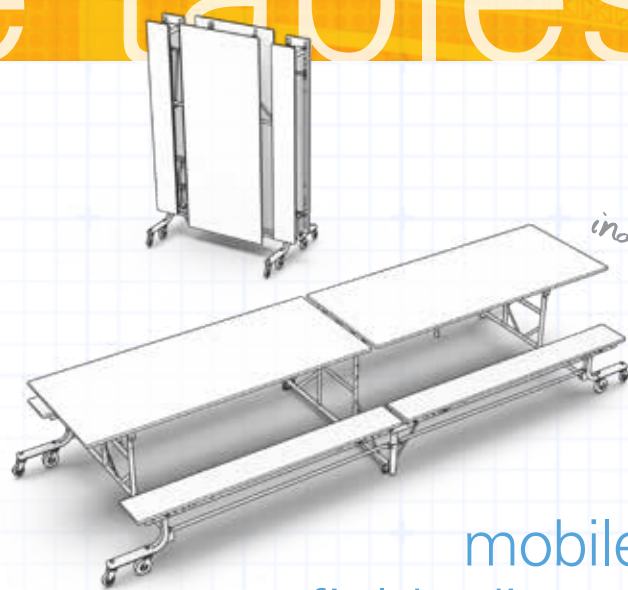

Space saving industry leader.

The 19F mobile table with field adjustable heights

FOLDS FLAT Compact storage — industry leader!

FIELD-ADJUSTABLE HEIGHT 27", 29" or 30" high.

LIFT ASSIST SYSTEM One of the easiest lifting tables on the market.

DOOR CLEARANCE Our tables easily clear standard 7' door frames.

*Light weight.
Easy to lift.*

VICTORY TABLE

The 59TV is one of the easiest lifting tables on the market

STANDARD HEIGHT FOR DOOR CLEARANCE Our tables easily clear standard 7' door frames.

CENTER LEGS holds up to the rigors of the school environment.

EdgeGuard™ polyurea edge resistant moisture, food traps, and extremely tamper resistant.

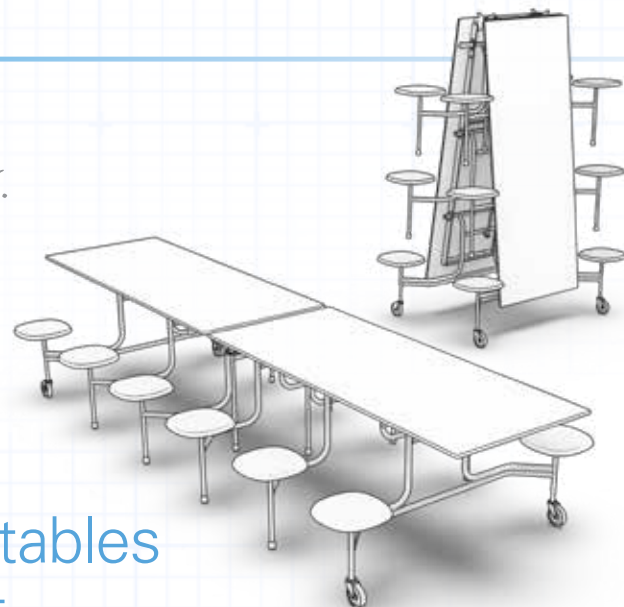

OPTION SAMPLES:

Frames:
Black



Laminates:
Match your school colors,
or stay neutral



Our designers will use your color selections to enhance your space.

Made in the USA

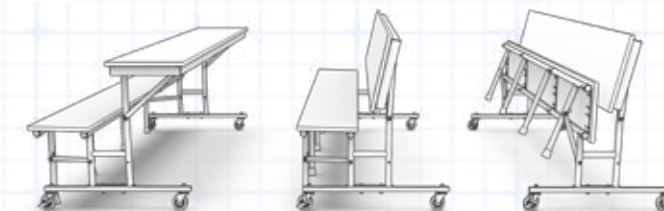

The ultimate in use flexibility.

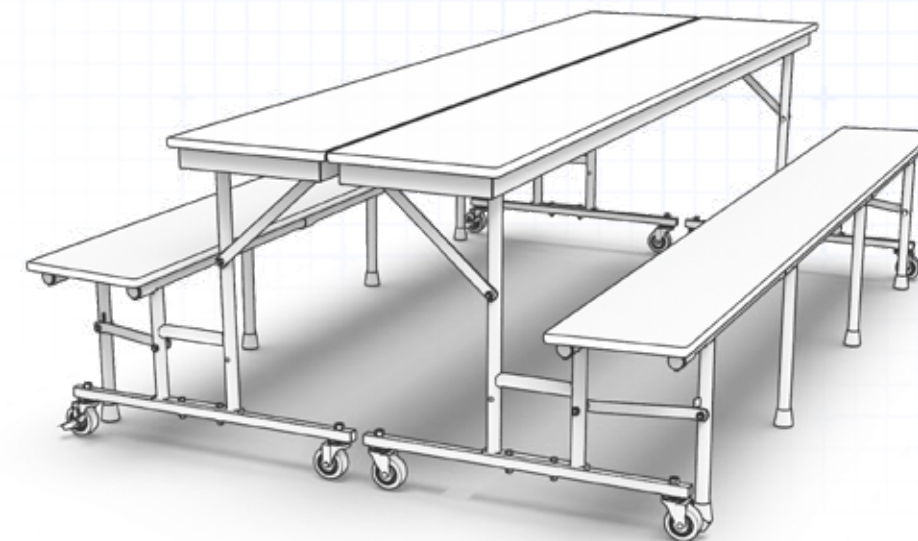

The 34 series converts to benches and/or tables

CONVERTIBLE BENCH/TABLE transforms from a single-sided table, to a comfortable bench, to a full-size cafeteria table.

25" HIGH TABLE MODEL offers lower table height. Smaller size perfect for Early Childhood settings.

EdgeGuard™ polyurea edge treatment that provides superior resistance to moisture, food traps, and is extremely tamper resistant.

furniture complementary tables & chairs

The 59T series provides the largest number of seating options

TORSION BARS AND TORSION SPRINGS work together to provide long-lasting lift assistance. One of the easiest lifting tables on the market.

WHEELCHAIR-ACCESSIBLE MODELS are 32" high and provide access for two to four wheelchairs.

STORAGE LATCH secures table in upright position. Locks table for storage or moving.

Great shape for group dining

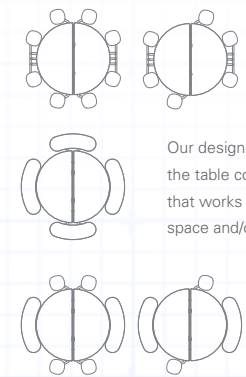

Our designers will select the table configurations that works best for your space and/or ADA needs.

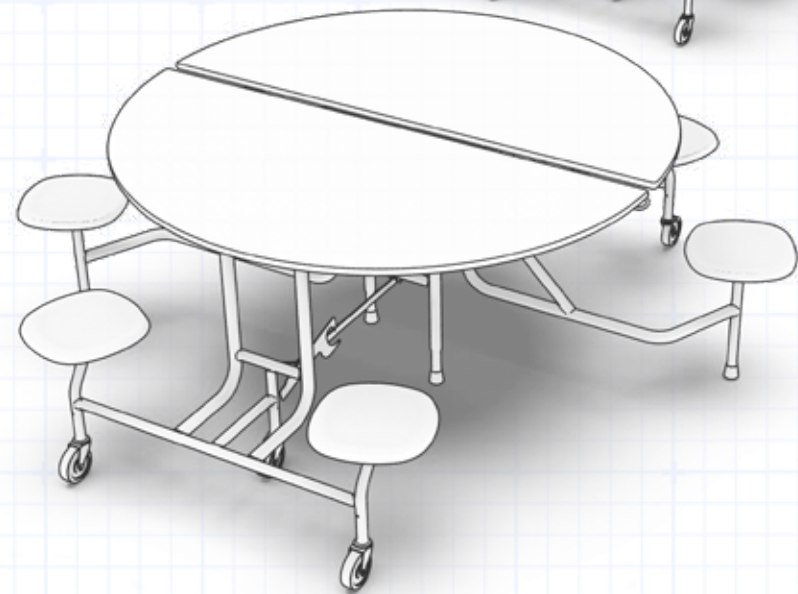

OPTION SAMPLES:

Frames:
Black



Stools/Laminates:
Match your school colors, or stay neutral



Our designers will use your color selections to enhance your space.

Made in the USA

OPTION SAMPLES:

Frames:
Black



Laminates:
Match your school colors, or stay neutral



Our designers will use your color selections to enhance your space.

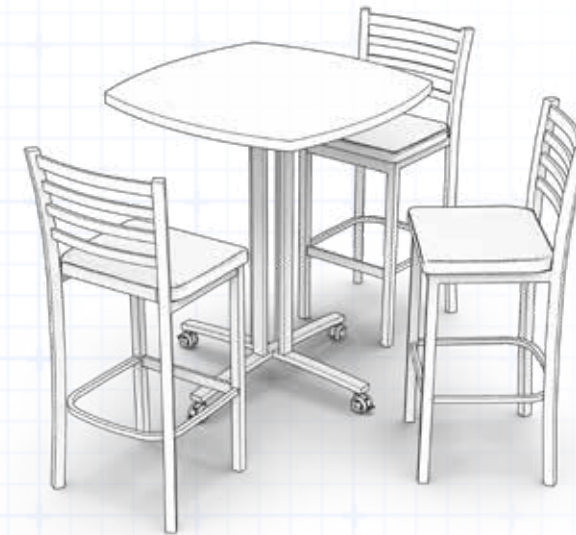

STORY

Unique table design with bold style

"SQUIRCLE" SHAPE rounded edges help soften the shape.

EdgeGuard™ polyurea edge treatment that provides superior resistance to moisture, food traps, and is extremely tamper resistant.

HEIGHTS: 29" standard and 42" cafe heights available.

Frames/seat:
Black frame, Walnut stained seat



ENCORE metal Metal framed seating with style and function

STANDARD AND PUB HEIGHT matched with your tables

DURABLE walnut stained wood seat.

PAIRS WELL with Conversation and Story tables.

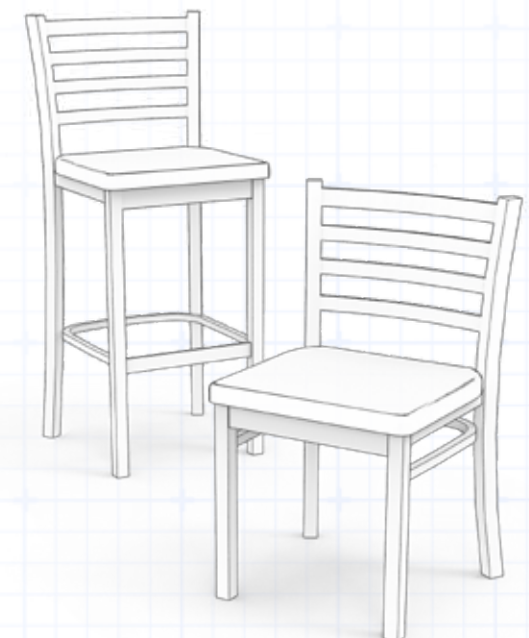

furniture booths and tables

OPTION SAMPLES:

Frames:
Black



Fiberglass:
Cappuccino, Steel Grey, Lapis
or Obsidian or combine

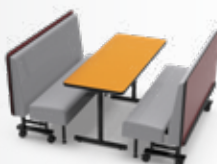

Laminates:
Match your school colors,
or stay neutral



Our designers will use your
color selections to enhance
your space.

AERO GO TABLE completes a booth set.
The Aero Go Table features built-in casters
that are activated by picking up the end of
the table allowing it to be easily moved.
When the table is flat it will not roll.



*Great for
multi-purpose
spaces.*

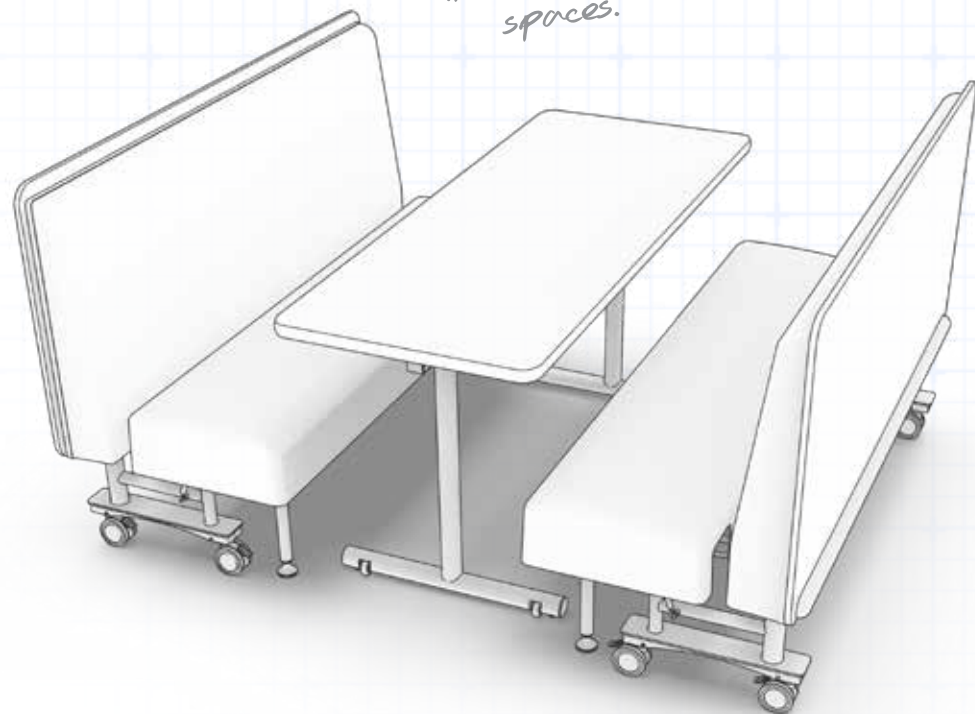

CHARIOT™ Mobile booths for flexible dining spaces

THE NEED FOR DINING SPACES TO SERVE MULTIPLE ROLES
requires dining furniture to be more mobile, flexible, easy to
reconfigure and storable.



CHARIOT® GO BENCH features a seat that folds
up, and built in casters allow the whole bench to be
wheeled away for easy reconfiguration or storage.



*Multi-colored laminate
table tops and
seat backs.*

Laminate choices:



Fiberglass color choices:

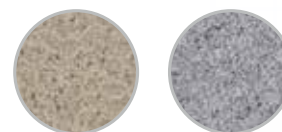

Cappuccino Steel Grey

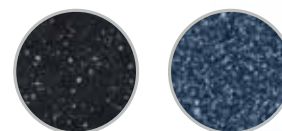

Obsidian Lapis

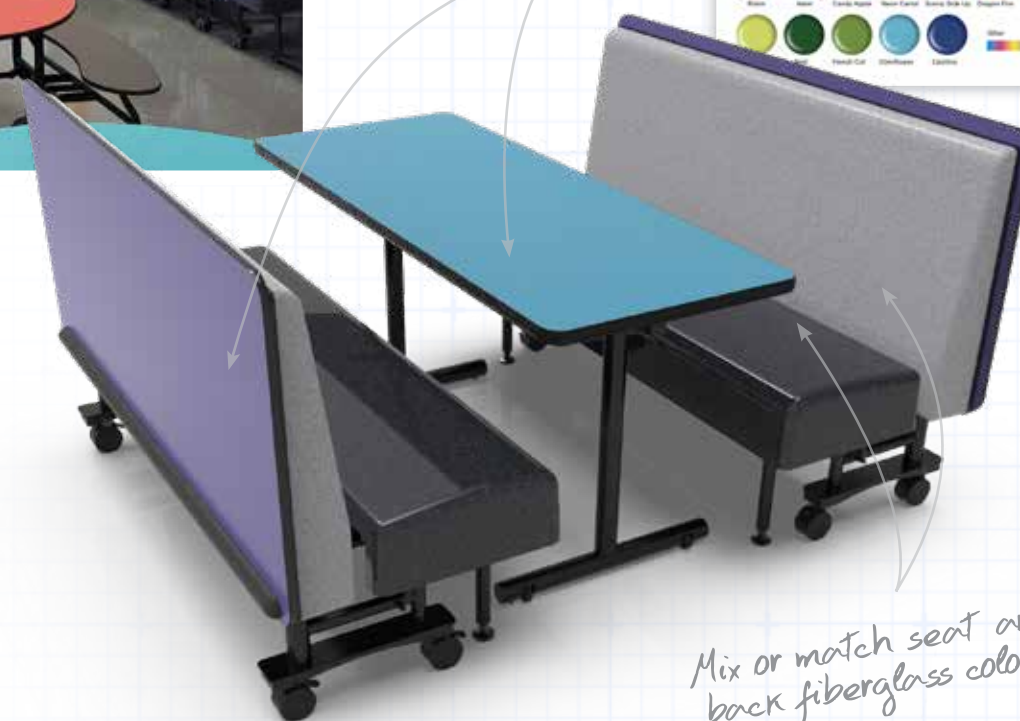

*Mix or match seat and
back fiberglass colors.*

café tables

furniture

palmer HAMILTON

conversation

Add unique seating options to a modern school cafeteria

FLEXIBLE SIZES Multiple heights/widths/lengths

CASTERS for room design options

PAIRS PERFECTLY with wheelchairs, Encore chairs

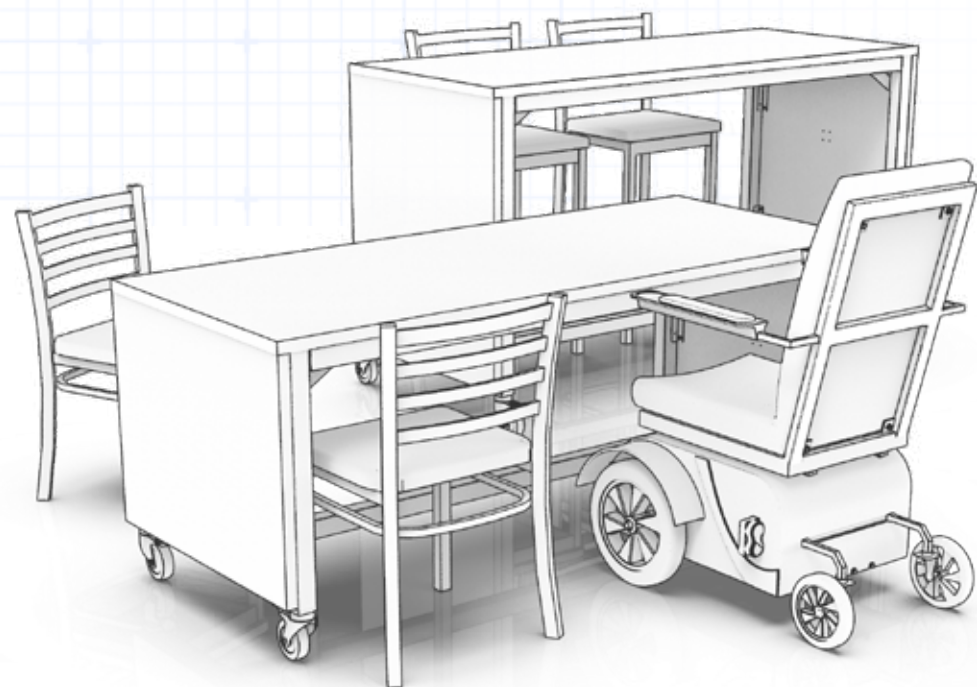

OPTION SAMPLES:

Frames:
Black



Laminates:

Match your school colors, or stay neutral



Our designers will use your color selections to enhance your space.

Made in the USA

Stools swing providing space saving seating.

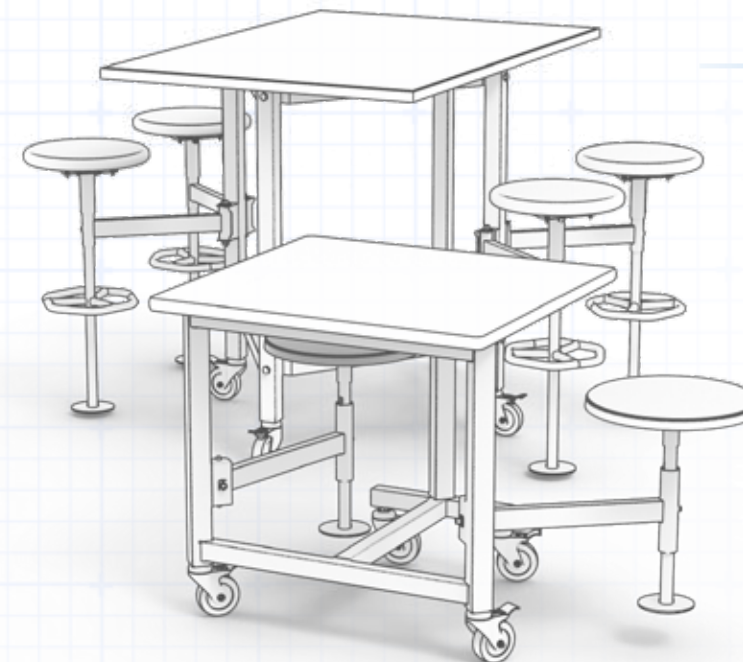

Mobility with a stylish design

STYLE AND FUNCTIONALITY is reflected in the Rally™ table. These are favorites with their swing out seats, durable locking casters and hooks for backpacks/coats.

MOVE TO RECONFIGURE your space. Lock into a row with side by side positioning.



Available in 30" and 42" heights

OPTION SAMPLES:

Frames:
Black



Laminates:

Match your school colors, or stay neutral



Our designers will use your color selections to enhance your space.

Made in the USA

worksheet

Toll Free: 800-788-1028 • info@palmerhamilton.com • www.PalmerHamilton.com | 143 S. Jackson Street • Elkhorn, WI 53121-1911

About the School

School Number:	School Name:
School Address:	
Borough:	Zip Code:
Contact Name:	Position:
Contact Email:	Contact Phone #:

Cafeteria & School Color Details

Current number of seats:	ADA seating (5% is standard percentage):
--------------------------	--

School Colors (select colors your campus would like to use in your graphics):

<input type="checkbox"/>	<input type="checkbox"/>	<input type="checkbox"/>	<input type="checkbox"/>	<input type="checkbox"/>	<input type="checkbox"/>	<input type="checkbox"/>	<input type="checkbox"/>	<input type="checkbox"/>	<input type="checkbox"/>
Magnolia	Mushroom	Battleship	Black Bird	Nightfall	Concord Grape	Gumball	Robin	Aster	Candy Apple
<input type="checkbox"/>	<input type="checkbox"/>	<input type="checkbox"/>	<input type="checkbox"/>	<input type="checkbox"/>	<input type="checkbox"/>	<input type="checkbox"/>	<input type="checkbox"/>	<input type="checkbox"/>	<input type="checkbox"/>
Neon Carrot	Sunny Side Up	Dragon Fire	Tangerine	Tennis Ball	Nori	Fresh Cut	Cornflower	Catalina	

Pantone™ Colors or other:

Graphics Selection

Graphic/Color Scheme (choose one)

<input type="checkbox"/>	<input type="checkbox"/>	<input type="checkbox"/>
Neutral	School Spirit	Vivid

Furniture Selections

Select your preferred styles of tables and booths. For descriptions of the products offered in this list, please go to this page.

<input type="checkbox"/>	<input type="checkbox"/>	<input type="checkbox"/>	<input type="checkbox"/>	<input type="checkbox"/>	Fiberglass Choices	
					<input type="checkbox"/>	<input type="checkbox"/>
19F Mobile Table	59TV Mobile Table	59T Mobile Table	34M Convertible Bench/Table	Chariot Mobile Booth	Cappuccino	Obsidian
<input type="checkbox"/>	<input type="checkbox"/>	<input type="checkbox"/>	<input type="checkbox"/>	<input checked="" type="checkbox"/>	<input type="checkbox"/>	<input type="checkbox"/>
				Walnut Stain	Black	Stool Colors
Rally Table with seating	Conversation Table	Story Table	Encore Metal seating		Navy	Lava
					Black	

Note: Due to limitations in the printing process, actual colors may appear slightly different.