

BLUERIDGE

Blueridge is a stationary and mobile laminate shelving collection created for high-use areas. Designed to coordinate with our Lenoir line of lounge seating, with matching curves and lengths.



FEATURES

- Shelves crafted with the high quality materials for strength and durability.
- Construction features 1" thick core with high pressure laminate on both sides with a 3mm PVC edge, and brass inserts for the strongest possible connection points.
- Shelving materials chosen to support the weight of books.
- Line offers straight, inner curve and outer curve shapes for creative space design.
- Laminate construction provides a wide array of color and pattern choices.

STATIONARY SHELVING

- Blueridge stationary shelving has a modular island/starter/adder/end design, which allows for easy reconfiguration.
- Available in single- or double-faced, straight and curved versions.
- Available heights: 30", 36", 42", 48", 60", 72", and 82".
- Units are available in 30", 31", 32", 33", 34", 35" or 36" widths.
- Curved units are available as inner or outer curves at 60" and 72" radii.

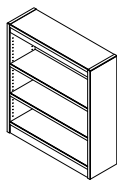

Island

Stand-alone, free-standing, with two end panels.

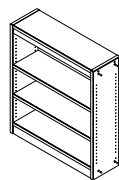

Starter

One end panel, one intermediate panel. Must be ordered with an end panel.

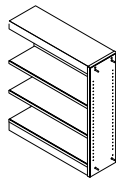

Adder

Run of shelves with one intermediate panel. Must be ordered with a starter and end panel.

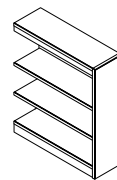

End

Ending point. Must be ordered with a starter unit.

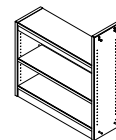

Height Adapter

Intermediate panel machined for different heights. Adapter is on left side. Only starters and adders can be height adapters.

Always build left to right

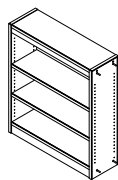

Starter

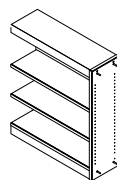

Adder

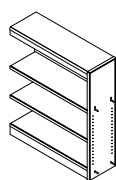

Height Adapter

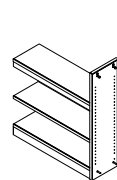

Height Adapter

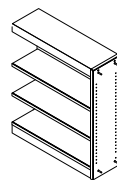

Adder

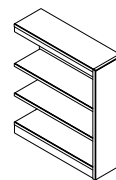

End

MOBILE SHELVING

- Blueridge mobile shelving is free-standing only.
- Available in single- or double-faced, straight and curved versions
- Available heights: 30", 36", 42", 48", 54" and 60"
- Straight shelves available in 30" and 36" widths.
- Curved shelves available in 60" and 72" radius, with approximately 36" widths. See page 10 for drawings.
- Single faced mobile shelves are 16" or 18" depths. Double faced is 24" depth
 - 3" heavy duty exposed locking casters used.
 - Units come standard with a double faced laminated back panel.



CONSTRUCTION

Sizes

- Selected sizes are nominal and actual dimensions vary depending on the selected unit type. Adder units and end units have a width equal to the nominal width whereas island and starter units have a width that is 1" larger than the nominal width, creating a run of shelving that is the selected nominal width on centers.

Creep Factor

- Due to variations in laminate thicknesses, there is a creep factor to the overall length of a shelving run where the actual length may be longer than expected. If there is a critical dimension that must be fit, it is the customer's responsibility to contact Palmer Hamilton.

Toe Kick

- A toe kick is used on stationary shelving and is constructed of 1" thick particle board core with a vertical grade high pressure laminate on both sides, with a 3mm PVC band on two long edges. The toe kick is machined for recessed specialty threaded connectors to engage metal inserts in the end and intermediate panels.



Modular Top

- A modular top is used on stationary shelving and is constructed of 1" thick particle board core with a vertical grade high pressure laminate on both sides, with a 3mm PVC band on two long edges. The modular top is machined for specialty threaded connectors to engage metal inserts in the end and intermediate panels.

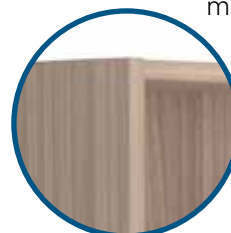

Horizontal panel

- The horizontal panel used on mobile shelving and is constructed of 1" thick particle board core with a vertical grade high pressure laminate on both sides, with a 3mm PVC band on all edges. The horizontal panel is machined for metal inserts to engage with specialty threaded connectors in the end and intermediate panels.

End and Intermediate Panel, Stationary Shelving

- The end and intermediate panels for stationary shelving are 1" thick particle board core with a vertical grade high pressure laminate on both sides, with a 3mm PVC band on two vertical edges and the top edge. The inside face(s) of the panels receive two rows of holes per face board to accept shelf pins, spaced 32mm apart on center. The panels are grooved to accept a 1/16" thick back panel unless otherwise noted. The panels are machined for metal inserts to engage with specialty threaded connectors in the toe kicks and modular tops.



End and Intermediate Panel, Mobile Shelving

- The end and intermediate panels for mobile shelving are 1" thick particle board core with a vertical grade high pressure laminate on both sides, with a 3mm PVC band on two vertical edges. Any curved mobile shelving unit over 36" in width will receive an intermediate panel. The inside face(s) of the panels receive two rows of holes per face board to accept shelf pins, spaced 32mm apart on center. The panels are grooved to accept a 1/16" thick back panel unless otherwise noted. The panels are machined for specialty threaded connectors to engage metal inserts in the horizontal panels.
- Note that straight mobile units are no wider than 36", so do not have intermediate panels.



Back Panel

- All double faced and single faced island units are two sheets of vertical grade high pressure laminate, glued back-to-back. Single faced perimeter shelving units are one sheet of vertical grade high pressure laminate glued to 1/8" MDF.

Beautifully crafted shelving to enhance media spaces.



Adjustable Shelf (Book Case)

- The adjustable shelves are constructed of 1" thick particle board core with a vertical grade high pressure laminate on both sides, with a 3mm PVC band on one long edges. The underside of the shelves are routed with a slot that rests on a pin at desired shelf height.

Picture Book Shelf

- The adjustable shelves are constructed of 1" thick particle board core with a vertical grade high pressure laminate on both sides, with a 3mm PVC band on one long edges. The underside of the shelves are routed to accept shelf pins. The top of the shelf receives five evenly spaced black wire dividers which are inserted into 3/16" diameter holes. Shorter width shelves may receive less than five dividers due to space limitations.

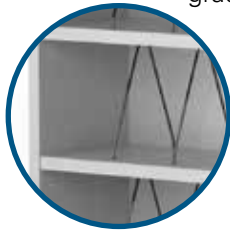

Fixed Shelf

- All shelving units 60" and higher require a shelf to be attached to the end and/or intermediate panels by means of (2) L-shaped brackets and pan head wood screws that will align with the shelf pin holes on vertical panels.

Metal Shelf

- The adjustable metal shell is constructed of 20 gauge steel and is 3/4" thick with the front and rear edges being square formed. The ends of the shelves are notched to accept shelf pins. The shelves are powder coated.

Metal Shelf Finishes

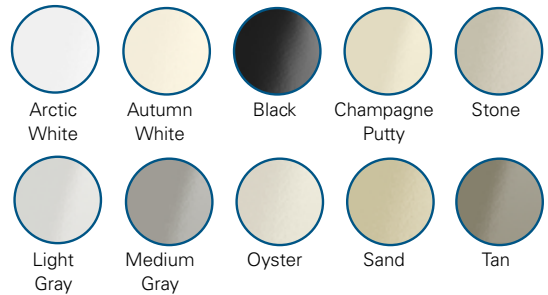



Corner Fillers

- The corner fillers are constructed of 1" thick particle board core with a vertical grade high pressure laminate on one side and a backing sheet on the back side. Solid hardwood cleats are provided for attachment to the shelving run and the wall.

NOTE: For a proper fit, corner fillers may require trimming on installation.

Top Fillers

- The top fillers are constructed of 1" thick particle board core with a vertical grade high pressure laminate on one side and a backing sheet on the back side, and receive a 3mm thick eased external band on one edge in the length dimension. Solid hardwood cleats are provided for attachment to the shelving run and the wall.

NOTE: For a proper fit, top fillers should be ordered oversized and require trimming on installation.

Face Fillers

- The face fillers are constructed of 1" thick particle board core with a vertical grade high pressure laminate on one side and a backing sheet on the back side. Solid hardwood cleats are provided for attachment to the shelving run and the wall.

NOTE: For a proper fit, face fillers should be ordered oversized and require trimming on installation.

Laminates

- **Group 1:** Choose your colors from Wilsonart® or Formica® laminates. See their websites for selections. For Wilsonart®, our standards are most colors in Type 335 laminate and finish type ending in -38 or -60. Exceptions apply, including colors that begin with "Y" or end with K-38 or K-60. Standard Formica® laminates are Grade 12 or Grade 20 ending in finish type -58 and -43.
- **Group 2:** Standard Pionite®, Nevamar®, and non-standard Wilsonart® laminates Type 335 and 107 Recycled Content, and finish types not ending in -38 or -60.
- **Group 3:** Wilsonart® Specialty Types 136 / 137 Chalkboard Laminates, Arborite®, and premium Formica®, Pionite®, and Nevamar®.
- **Group 4:** Non-Standard Premium Wilsonart® Laminate Types 362 (VDL, Y-Type), 156 / 336 (Markerboard), 376-HD / 366 Wilsonart® HD, and 515 Compact Laminate.
- **All premium laminates** are subject to an upcharge.



INSTALLATION

Each straight stationary shelving unit needs to be attached to a wall or secure structure per local code. Hardware is customer supplied.

WARRANTY

15 year standard warranty. See our website.

SHIPPING

Ships knocked down. Note that back panels are one solid piece, so the flat packaging dimensions will be at least the width and length of the highest and / or widest unit. We rarely ship one unit at a time, therefore we package units to utilize the best shipping practices.

Please contact us for the specific shipping dimensions, weight and cost of your order.

SPECIFICATIONS

Number and Spacing of Shelves - Stationary

Shelves are adjustable, except for bottom shelf and fixed shelf in units 60" or higher. The bottom shelf is provided as a cover of the base. It is not intended to be moved.

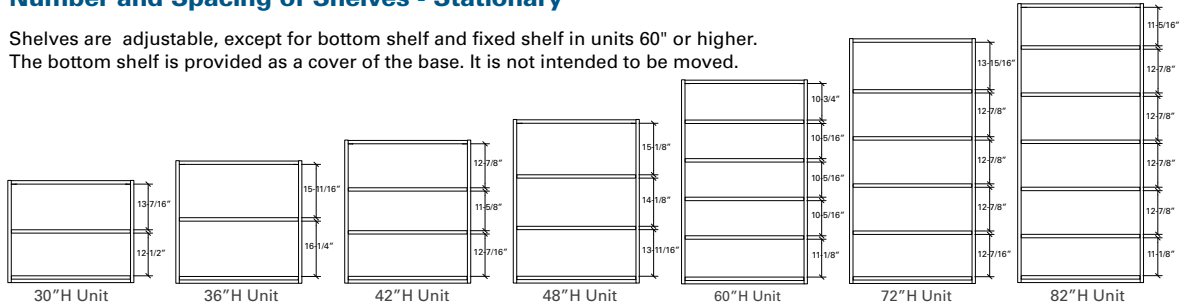

Number and Spacing of Shelves - Mobile

Shelves are adjustable, except for fixed shelf in units 60" high.

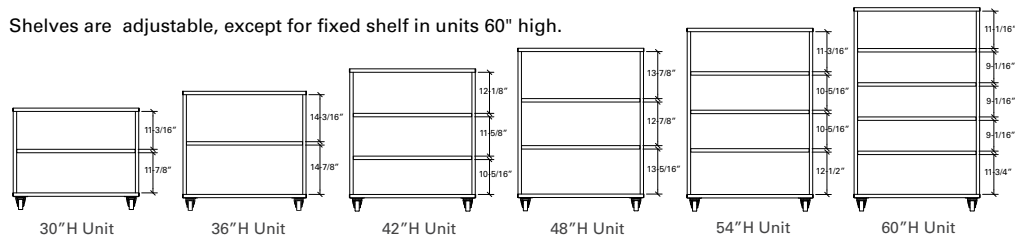

SPECIFICATIONS

Straight Shelving

MODEL NUMBER	HEIGHT (in)	WIDTH (in)	DEPTH (in)	SHELVES	CONFIGURATION
Stationary Single-Faced Shelving					
BL-SH-3012	30	30, 31, 32, 33, 34, 35 or 36	12	1	ISLAND, STARTER*, ADDER*, END
BL-SH-3612	36	30, 31, 32, 33, 34, 35 or 36	12	1	ISLAND, STARTER*, ADDER*, END
BL-SH-4212	42	30, 31, 32, 33, 34, 35 or 36	12	2	ISLAND, STARTER*, ADDER*, END
BL-SH-4812	48	30, 31, 32, 33, 34, 35 or 36 8	12	2	ISLAND, STARTER*, ADDER*, END
BL-SH-6012	60	30, 31, 32, 33, 34, 35 or 36	12	4	ISLAND, STARTER*, ADDER*, END
BL-SH-7212	72	30, 31, 32, 33, 34, 35 or 36	12	4	ISLAND, STARTER*, ADDER*, END
BL-SH-8212	82	30, 31, 32, 33, 34, 35 or 36	12	5	ISLAND, STARTER*, ADDER*, END

Stationary Double-Faced Shelving

(each side)

BL-SH-3024	30	30, 31, 32, 33, 34, 35 or 36	24	1	ISLAND, STARTER*, ADDER*, END
BL-SH-3624	36	30, 31, 32, 33, 34, 35 or 36	24	1	ISLAND, STARTER*, ADDER*, END
BL-SH-4224	42	30, 31, 32, 33, 34, 35 or 36	24	2	ISLAND, STARTER*, ADDER*, END
BL-SH-4824	48	30, 31, 32, 33, 34, 35 or 36	24	2	ISLAND, STARTER*, ADDER*, END
BL-SH-6024	60	30, 31, 32, 33, 34, 35 or 36	24	4	ISLAND, STARTER*, ADDER*, END
BL-SH-7224	72	30, 31, 32, 33, 34, 35 or 36	24	4	ISLAND, STARTER*, ADDER*, END
BL-SH-8224	82	30, 31, 32, 33, 34, 35 or 36	24	5	ISLAND, STARTER*, ADDER*, END

All straight shelving units available with standard, metal or picture book shelves.
 Curved units available with standard or picture book shelves.
 Finished backs available at no extra charge for Stationary units, standard on Mobile.
 *Adapters available for Stationary units to share a wall for height differences.

Stationary Single-Faced Shelving

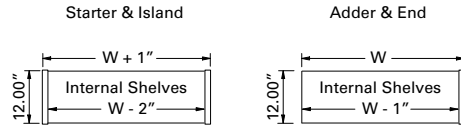

Stationary Double-Faced Shelving

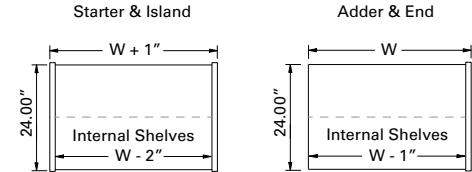

SPECIFICATIONS

Straight Shelving

MODEL NUMBER	HEIGHT (in)	WIDTH (in)	DEPTH (in)	SHELVES	CONFIGURATION
Mobile Single-Faced Shelving					
BL-MS-30	30	30, 36	16, 18	1	MOBILE BOOKCASE
BL-MS-36	36	30, 36,	16, 18	1	MOBILE BOOKCASE
BL-MS-42	42	30, 36	16, 18	2	MOBILE BOOKCASE
BL-MS-48	48	30, 36	16, 18	2	MOBILE BOOKCASE
BL-MS-54	54	30, 36	16, 18	3	MOBILE BOOKCASE
BL-MS-60	60	30, 36	16, 18	4	MOBILE BOOKCASE
Mobile Double-Faced Shelving (each side)					
BL-MS-3024	30	30, 36	24	1	MOBILE BOOKCASE
BL-MS-3624	36	30, 36	24	1	MOBILE BOOKCASE
BL-MS-4224	42	30, 36	24	2	MOBILE BOOKCASE
BL-MS-4824	48	30, 36	24	2	MOBILE BOOKCASE
BL-MS-5424	54	30, 36	24	3	MOBILE BOOKCASE
BL-MS-6024	60	30, 36	24	4	MOBILE BOOKCASE

All straight shelving units available with standard, metal or picture book shelves.
 Curved units available with standard or picture book shelves.
 Finished backs available at no extra charge for Stationary units, standard on Mobile.
 *Adapters available for Stationary units to share a wall for height differences.

Mobile Single-Faced Shelving

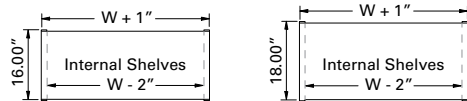

Mobile Double-Faced Shelving

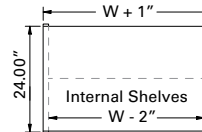

SPECIFICATIONS

Curved Shelving

MODEL NUMBER	HEIGHT (in)	RADIUS	DEPTH (in)	SHELVES	CONFIGURATION
Stationary Single-Faced Shelving					
BL-SH-3012	30	60" or 72", Inner or Outer Curve	12	1	ISLAND, STARTER*, ADDER*, END
BL-SH-3612	36	60" or 72", Inner or Outer Curve	12	1	ISLAND, STARTER*, ADDER*, END
BL-SH-4212	42	60" or 72", Inner or Outer Curve	12	2	ISLAND, STARTER*, ADDER*, END
BL-SH-4812	48	60" or 72", Inner or Outer Curve	12	2	ISLAND, STARTER*, ADDER*, END
BL-SH-6012	60	60" or 72", Inner or Outer Curve	12	4	ISLAND, STARTER*, ADDER*, END
BL-SH-7212	72	60" or 72", Inner or Outer Curve	12	4	ISLAND, STARTER*, ADDER*, END
BL-SH-8212	82	60" or 72", Inner or Outer Curve	12	5	ISLAND, STARTER*, ADDER*, END

Stationary Double-Faced Shelving

(each side)

BL-SH-3012	30	60" or 72", Inner or Outer Curve	24	1	ISLAND, STARTER*, ADDER*, END
BL-SH-3612	36	60" or 72", Inner or Outer Curve	24	1	ISLAND, STARTER*, ADDER*, END
BL-SH-4212	42	60" or 72", Inner or Outer Curve	24	2	ISLAND, STARTER*, ADDER*, END
BL-SH-4812	48	60" or 72", Inner or Outer Curve	24	2	ISLAND, STARTER*, ADDER*, END
BL-SH-6012	60	60" or 72", Inner or Outer Curve	24	4	ISLAND, STARTER*, ADDER*, END
BL-SH-7212	72	60" or 72", Inner or Outer Curve	24	4	ISLAND, STARTER*, ADDER*, END
BL-SH-8212	82	60" or 72", Inner or Outer Curve	24	5	ISLAND, STARTER*, ADDER*, END

All straight shelving units available with standard or picture book shelves.
 Finished backs available at no extra charge for Stationary units, standard on Mobile.
 Adapters available for stationary units to share a wall for height differences.

Curved Shelving - Stationary

60" Radius

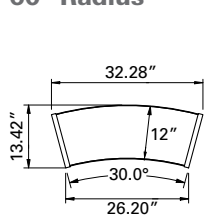

60" Radius, Inner Curve

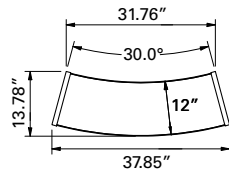

60" Radius, Outer Curve

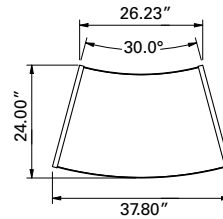

60" Radius, Double Faced

72" Radius

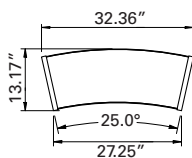

72" Radius, Inner Curve

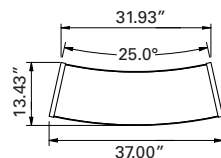

72" Radius, Outer Curve

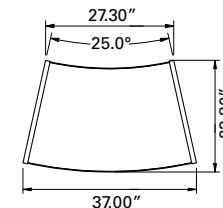

72" Radius, Double Faced

DIMENSIONS

Curved Shelving

MODEL NUMBER	HEIGHT (in)	RADIUS	DEPTH (in)	SHELVES	CONFIGURATION
Mobile Single-Faced Shelving					
BL-MS-30	30	60" or 72", Inner or Outer Curve	16, 18	1	MOBILE BOOKCASE
BL-MS-36	36	60" or 72", Inner or Outer Curve	16, 18	1	MOBILE BOOKCASE
BL-MS-42	42	60" or 72", Inner or Outer Curve	16, 18	2	MOBILE BOOKCASE
BL-MS-48	48	60" or 72", Inner or Outer Curve	16, 18	2	MOBILE BOOKCASE
BL-MS-54	54	60" or 72", Inner or Outer Curve	16, 18	3	MOBILE BOOKCASE
BL-MS-60	60	60" or 72", Inner or Outer Curve	16, 18	4	MOBILE BOOKCASE

Mobile Double-Faced Shelving

(each side)

BL-MS-3024	30	60" or 72", Double Faced	24	1	MOBILE BOOKCASE
BL-MS-3624	36	60" or 72", Double Faced	24	1	MOBILE BOOKCASE
BL-MS-4224	42	60" or 72", Double Faced	24	2	MOBILE BOOKCASE
BL-MS-4824	48	60" or 72", Double Faced	24	2	MOBILE BOOKCASE
BL-MS-5424	54	60" or 72", Double Faced	24	3	MOBILE BOOKCASE
BL-MS-6024	60	60" or 72", Double Faced	24	4	MOBILE BOOKCASE

All straight shelving units available with standard or picture book shelves.
 Finished backs available at no extra charge for Stationary units, standard on Mobile.
 Adapters available for stationary units to share a wall for height differences.

Curved Shelving - Mobile

60" Radius

Inner Curve

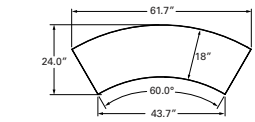
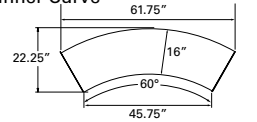

Double Faced

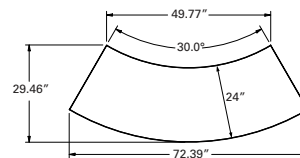

Outer Curve

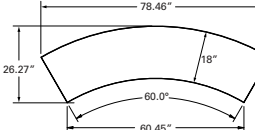
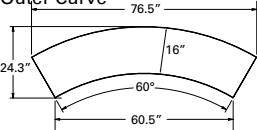

72" Radius

Inner Curve

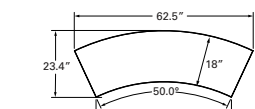
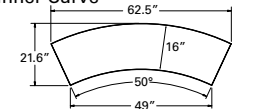

Double Faced

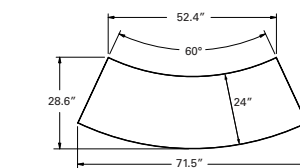

Outer Curve

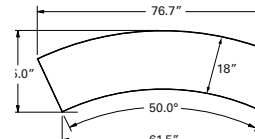
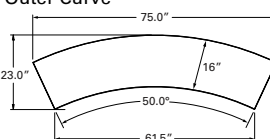

LAYOUTS

Curved Stationary Shelving 60" Radius

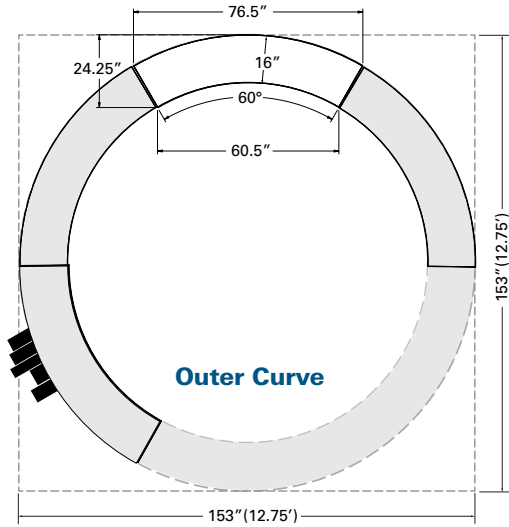
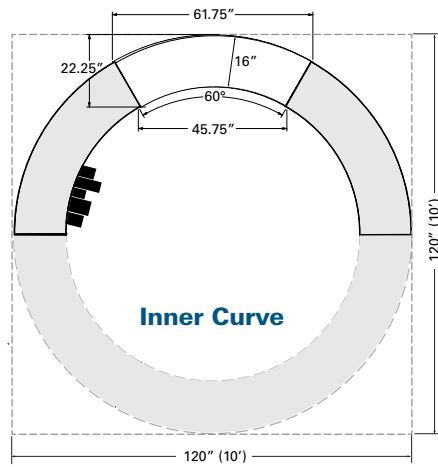

Curved Stationary Shelving 72" Radius

