

SERVING LINE

Utility Counter

Palmer Hamilton designs cafeteria environments featuring high-quality hot and cold serving counters, cashier stands, and accessory modules. The sample shown illustrates the type of unit we can create and customize to meet your specific needs.

PART #	DESCRIPTION	DIMENSIONS	LIST PRICE
PH-ULS72	Utility Counter with solid surface top, laminated wood panels and standard corners. Front panel, 4 side panels, standard feet, polished toe kicks, plate shelf, two angled front corners, power for counter top unit (in addition to this unit), back splash.	72"L x 35"W x 34"H	\$19,237
PH-CLS66	Cold Food Counter with solid surface top, laminated wood panels with standard corners, front and back panels, two side panels, standard feet, polished toe kicks, operator side doors, slim cold well, 60" island food shield with polished finish and LED lights, four grommet holes for silverware cups.	66"L x 35"W x 34"H	\$26,440

Pricing subject to change based on model and configuration. Contact us for current pricing.
 Additional units are available in a variety of sizes and configurations, including custom graphics. Contact us for design and pricing.

PH-ULS72

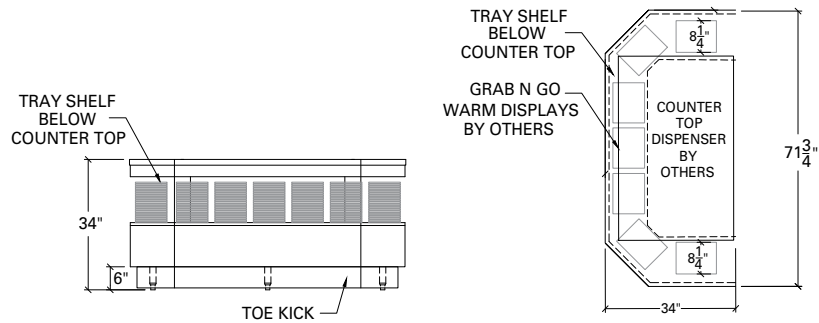

PH-CLS66

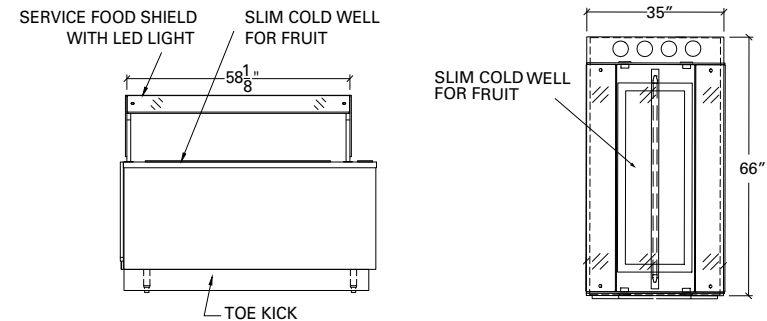

Associations and Purchasing Groups:

See our website for our full list of regional and state contracts.

